

# Lixel L2 Pro

User Manual(V2.4)

2026.1

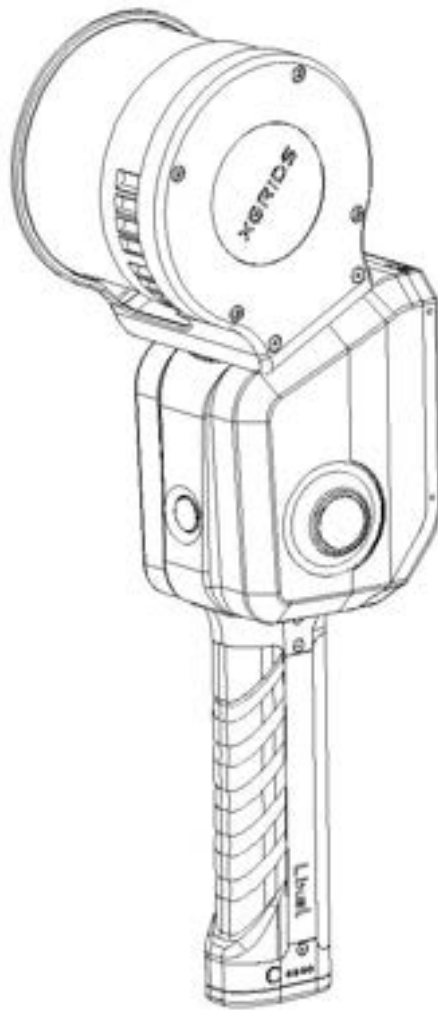

# Contents

1 Product Overview .....	1
2 Basic Operation .....	2
2.1 Battery Installation .....	2
2.2 Function Key Operation .....	2
2.3 Indicator Light Descriptions .....	3
2.4 Data Transfer Instructions .....	4
2.5 Battery Charging Instructions .....	4
2.6 Firmware Upgrade .....	5
2.7 Usage Precautions .....	6
3 Device Activation and Connection .....	7
3.1 LixelGO Introduction .....	7
3.2 Recommended installation environment .....	7
3.3 Device Activation .....	8
4 Scan .....	27
4.1 Connected the device .....	27
4.2 Scan Mode Settings (L2 Pro Only) .....	29
4.3 Start Scanning .....	31
4.4 Rendering Mode .....	32
4.5 Stop Scanning .....	33
4.6 View Model .....	34
4.7 Downloading Scanned Data .....	36

## XGRIDS Lixel L2 Pro User Manual

---

4.8 Data Project File Structure .....	37
4.9 XGRIDS LAB .....	39
5 Acquire Point Cloud Data with Absolute Coordinate .....	40
5.1 Through Existing Ground Control Points (GCP) .....	40
5.2 Through the RTK Module .....	47
6 Measure Point .....	55
6.1 Usage Scenario/Requirement .....	56
6.2 Example .....	56
7 Appendix .....	59
7.1 Specifications .....	59
7.2 Protective Case Slots .....	64
7.3 Accessories .....	64

# 1 Product Overview

The Lixel L2 Pro is a highly integrated, high-precision handheld 3D real-world reconstruction device that supports real-time data viewing, instant reconstruction upon capture, and ready-to-use data export. It is available in three models based on LiDAR configurations: 16-channel 120m, 32-channel 120m, and 32-channel 300m. Its key features include:

1. **Real-time RTK Integration:** This function enables direct output of point clouds in the projected coordinate system without post-processing, eliminating layering issues in the RTK-assisted point clouds.
2. **Real-time RTK Measurement:** When transitioning from outdoor to indoor environments, users can directly obtain absolute RTK coordinates for indoor locations using the device.
3. **High-precision Point Cloud Post-processing:** With RTK disconnection or when control points are spaced less than 100m apart, the post-processed data achieves a precision (RMSE) of 3cm.
4. **Exceptional Point Cloud Density and Color:** Capable of reaching up to 1 million points per square meter.

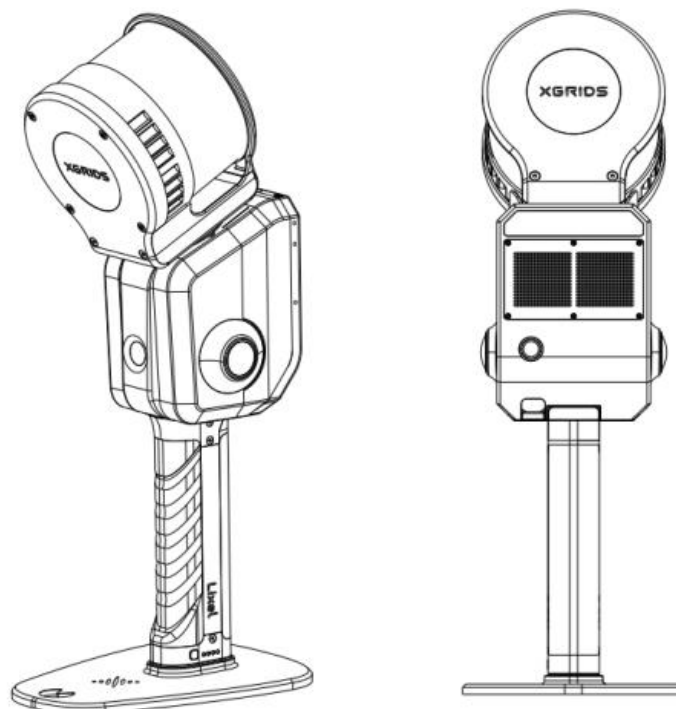

## 2 Basic Operation

### 2.1 Battery Installation

1. Open the battery lock lever.
2. Insert the battery into the bottom of the device along the guiding slot, ensuring it is fully inserted.
3. Press the lever back to lock the battery in place.

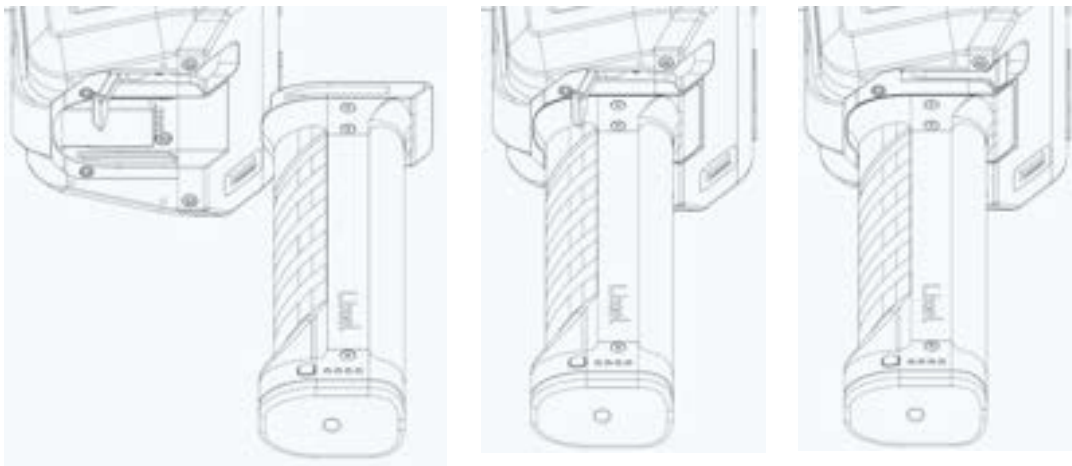

Note: Failure to lock the battery securely may result in the device slipping.

### 2.2 Function Key Operation

Function	Button Operation	Device Status
Power On	Press and hold for 4 seconds	The indicator light will change from slow flashing blue to solid green, indicating the device has entered standby mode.
Power Off	Press and hold for 4 seconds	While in standby mode, long press for 4 seconds. The indicator light will change from solid green to flashing white, indicating the system is saving data. The device powers off once the indicator turns off.

Start Scanning	In standby mode, double-click the button.	The indicator light will switch from solid green to fast-flashing green, then slow-flashing green. The LiDAR will begin to rotate, indicating that scanning has successfully started, and the device has entered scanning mode.
Stop Scanning	In scanning mode, double-click the button.	The indicator light will change from slow-flashing green to fast-flashing green, then solid green. The LiDAR will stop rotating, indicating that scanning has successfully stopped, and the device has returned to standby mode.
Control Point Collection	In scanning mode, single-click the button.	The indicator light will stay on for about 1 second, then return to slow-flashing green. This indicates successful control point recording.
Switch to USB Mode	In standby mode, single-click + indicator light turns white + single-click	After a single click, the indicator light will turn white and remain for up to 3 seconds. During this white light period, single-click the button again to switch to USB mode. If no further action is taken within 3 seconds, the device will remain in its original mode.

Note:

1. Before starting the scan, ensure the device is placed on a flat surface. Once the LiDAR begins rotating after initiating the scan, you can move the device to begin scanning.
2. During the stop-scanning process, a fast-flashing green light indicates that the device is saving the scan files. Powering off during this time may result in file loss or incomplete file saving.
3. The saving period (device light fast-flash green) after stopping the scan may vary based on the size of the scanned environment.

## 2.3 Indicator Light Descriptions

Indicator Light Status	Meaning
No light	Device not started
Slow-flashing green light	Scanning mode

Solid green light	Standby mode
Solid blue light	USB mode
Solid yellow light	Device not activated
Solid red light	System error
Slow-flashing blue light (~30s)	Powering on
Solid white light	Switching between standby and USB mode
Fast-flashing green light	Scan starting/stopping
Light alternates between red and green	Upgrading

## 2.4 Data Transfer Instructions

To transfer data, connect the device to a computer using the provided USB 3.1 cable while the device is in standby mode. Use the app or the power button to switch to USB mode. Once the device is recognized, you can proceed with data copying.

Notes:

The USB mode will automatically disable after a device restart.

If you want to continue scanning after enabling USB mode without powering off or disconnecting the device, you must manually exit USB mode.

Using other USB cables may result in slower transfer speeds or other issues.



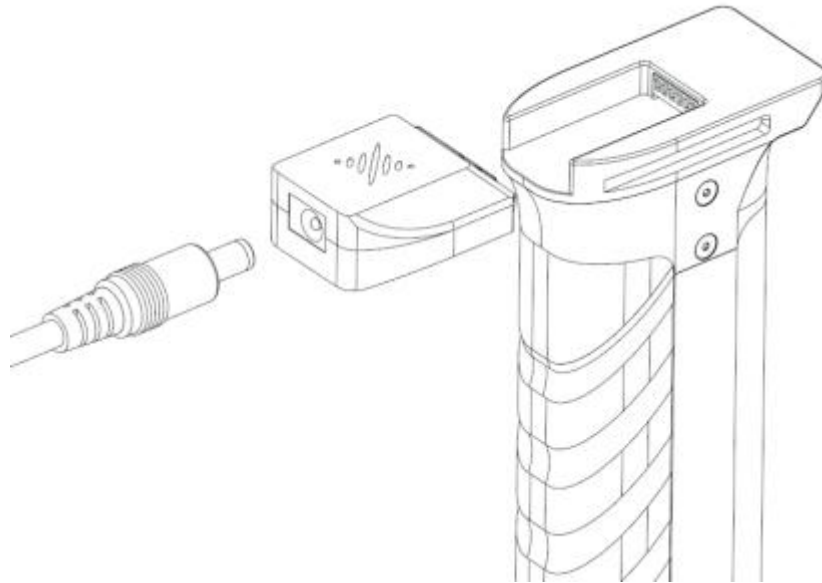

A common problem could be that the USB cable could only be recognized in one direction. When rotating the Type C port 180 degrees, with the other side pointing up, it cannot be recognized by the device.

## 2.5 Battery Charging Instructions



To charge the battery, use the provided charging cable to connect the charging port to the battery. Press the button on the battery to display the current battery level.

Charging Time: Approximately 2 hours. During charging, the indicator light will show the current battery level as described below:

Flashing Pattern	Battery Level
	0-24%
	25%-49%
	50%-74%
	75%-99%

## 2.6 Firmware Upgrade

According to the prompts in the app, you can perform a firmware upgrade on the device. Firmware upgrades are divided into two types: major upgrades and minor upgrades. Minor upgrades can be completed directly through the app. If the app indicates that a major upgrade is required, the upgrade process is as follows:

1. Download the necessary major firmware package from the official website (typically, major firmware packages are larger than 1GB).
2. Switch the device to USB drive mode and copy the firmware to the root directory of the device's disk.
3. Power off the device, then restart it. After restarting, the device will automatically enter firmware upgrade mode.

## **2.7 Usage Precautions**

1. The Lixel L2 PRO is a precision surveying device. Dropping it or subjecting it to impacts may cause damage, leading to malfunctions or inaccurate measurements.
2. Ensure that the LiDAR rotates freely without any external obstructions when the device is powered on. At the same time, avoid obstructing the radar and camera's field of view, as this may cause mapping failures and color anomalies..
3. The metal base ensures stability and thus accuracy during initialization process. Avoid initializing on uneven surfaces, as this may cause initialization failure or thicker mapping layers.
4. When using the device, try to avoid rapid rotations or fierce shaking, as excessive movement may lead to mapping failures or reduced mapping accuracy. Additionally, when using other vehicles like cars for mapping, place proper shock absorption to prevent high-frequency vibration.
5. The Lixel L2 Pro is rated IP54 for water resistance. Do not use the device in conditions exceeding this protection level. For device maintenance, clean the device with a soft, dry cloth or the cloth provided in the case.
6. Do not block the ventilation areas during operation. Significant obstruction can reduce cooling efficiency, causing the device to overheat and shut down automatically.

## 3 Device Activation and Connection

### 3.1 LixelGO Introduction

LixelGO is a mobile app that comes with the Lixel L2 Pro scanner. Its functions include viewing and managing projects. With this app, the management of digital 3D spatial assets is streamlined and efficient.

#### Android Version

Scan the code to install the latest version of the app.

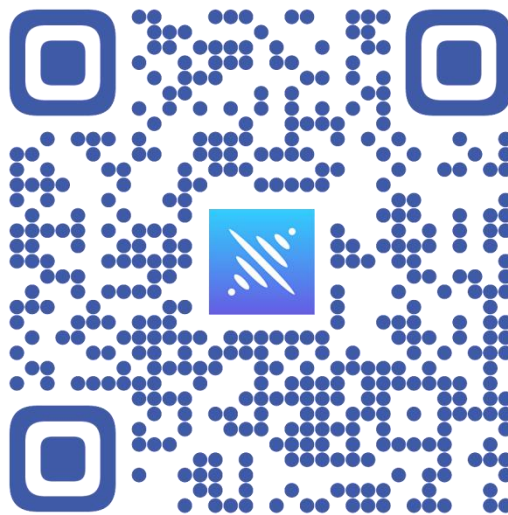

#### IOS Version

Go to the App Store and search LixelGo to download and install the latest version of the app.

### 3.2 Recommended installation environment

Recommended phone configuration :

Module	Specs
CPU	Recommended Snapdragon series, preferably Snapdragon 8 or above
Random Access	Minimum 8GB

Memory	
Display chip	It is best to have an independent display chip
Other	it needs to support Bluetooth and Hotspot function; larger storage memory preferred; and longer battery life preferred.

**Recommended :**

Brand	Product	Processor CPU	Random Access Memory	Graphics card GPU
VIVO	IQOO NEO 6	The first generation Snapdragon 8 + mobile platform	12GB	Adreno 730
Redmi	Redmi K50 E-sports Edition	Qualcomm Snapdragon 8 Gen 1	8GB	Adreno 730
Huawei	Huawei P50E	Snapdragon 778G	8GB	Adreno 642L
OPPO	OPPO K10	Dimensity 8000-MAX Mobile Platform	8GB	Mali-G510 MC6

### 3.3 Device Activation

#### 1. Register and log in to LixelGO.

After installing LixelGO, open the app and click Use now to enter the login/registration interface. New users should choose to register by email or mobile phone number. Registered users can log in by account and password or mobile phone verification SMS.

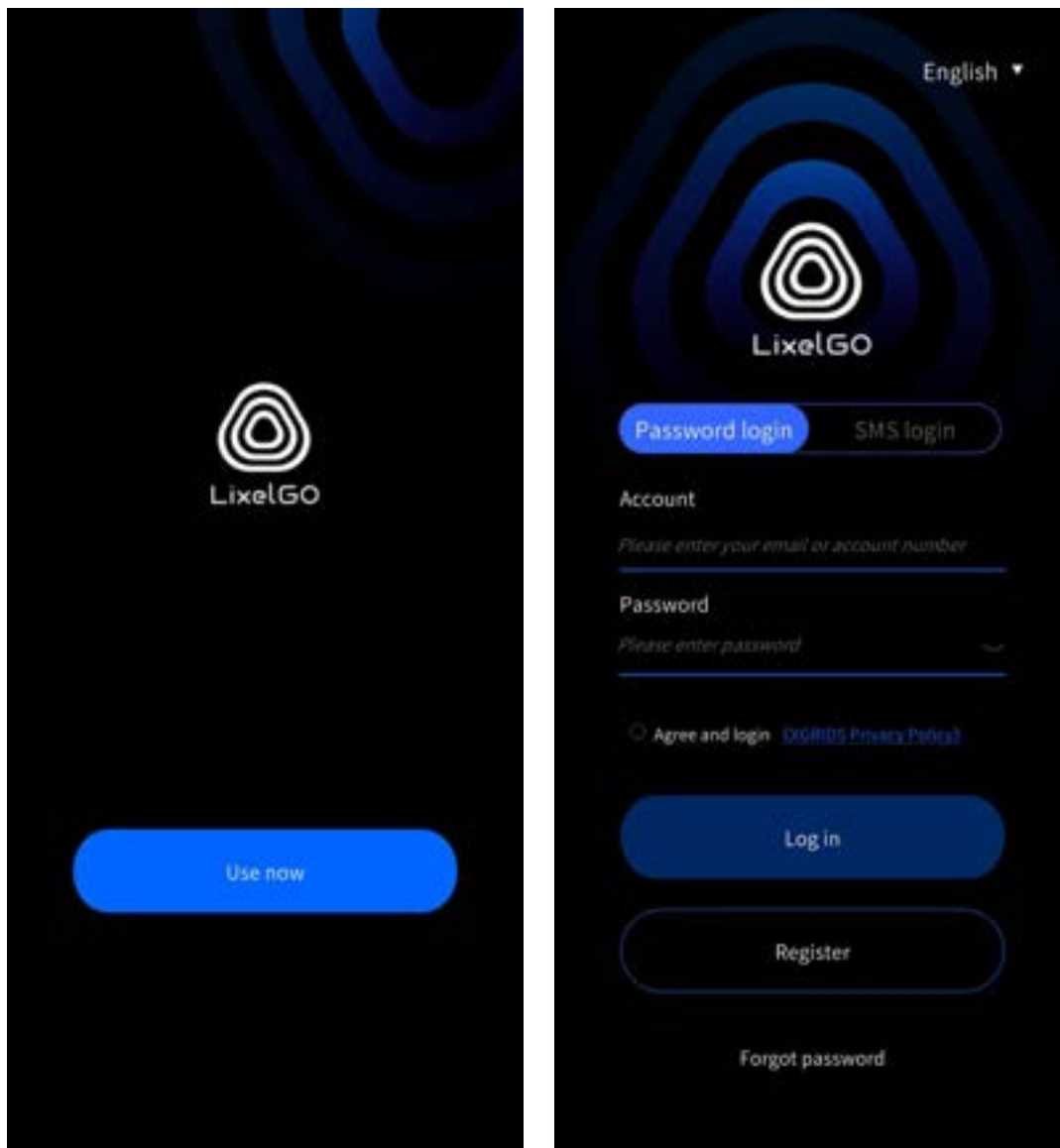

## 2. Forgot password

If you have registered an account but forgot your password, you can click "Forgot password" to reset it through the registered phone number or email.

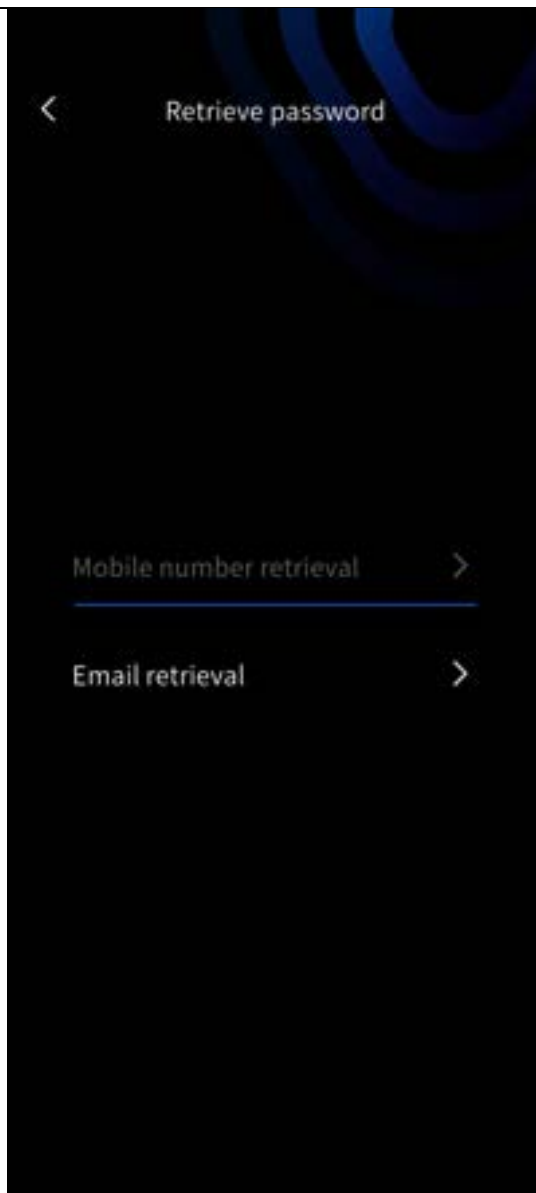

### 3. Switch language

By clicking on the upper right corner of the screen to switch languages. The app currently supports Simplified Chinese and English.



## 4. Add a New Device

### Android version

Press and hold the power button to turn on the handheld scanning device. The indicator light changing from fast-blinking blue to steady green indicates a successful startup.

Quick Connect Mode:

Firmware 3.2.1+ & LixelGO 1.3.0 : Use Quick Connect Mode by default

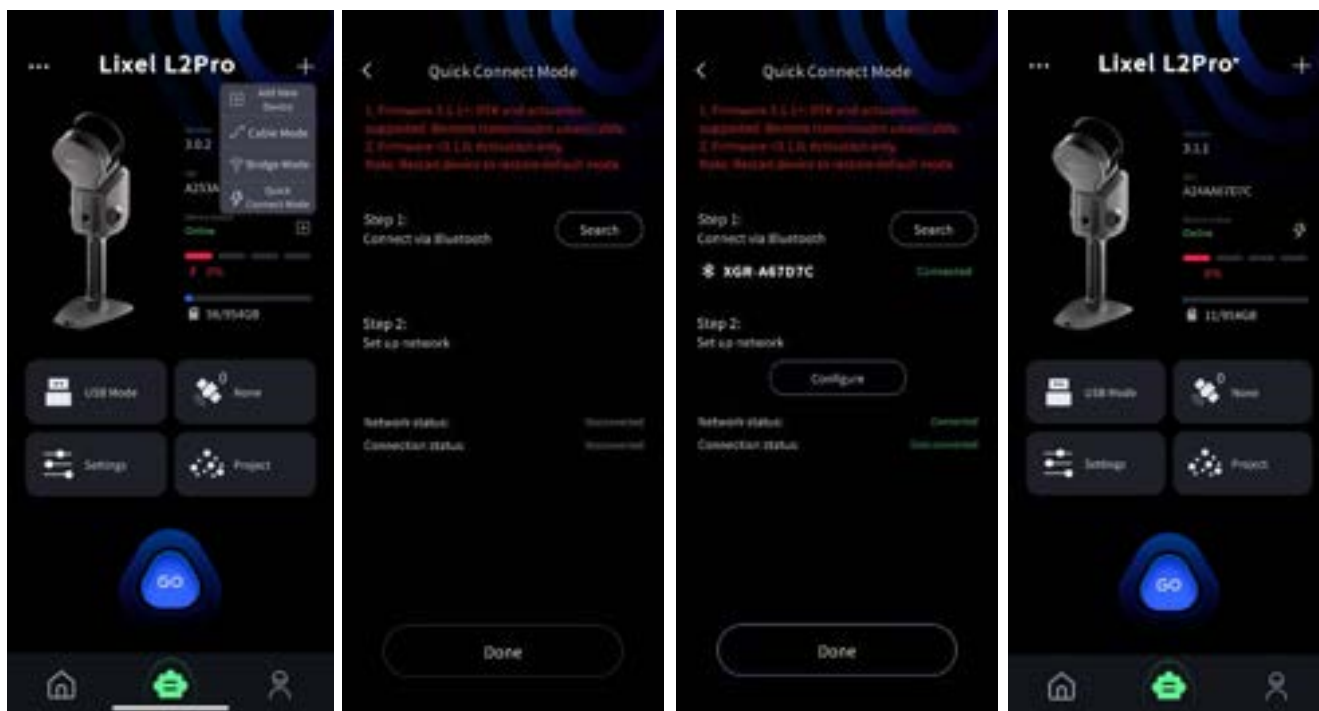

**Direct Connect Mode:** Click Hotspot mode, allow permissions, and then follow the steps.

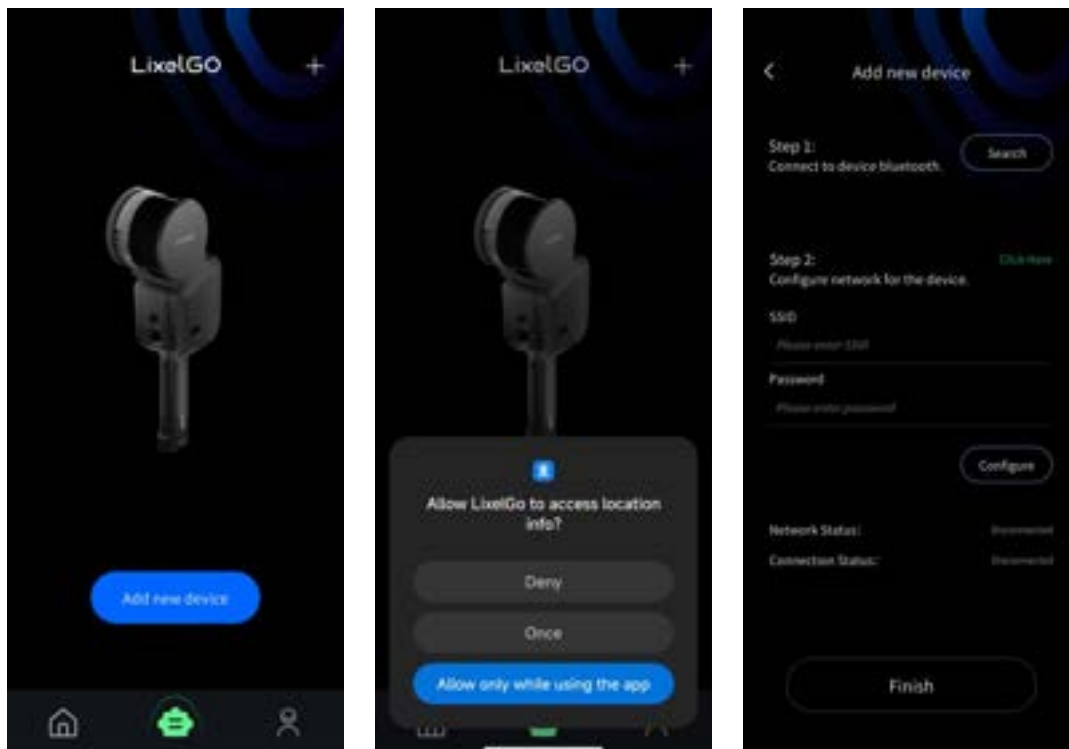

First, turn on the phone's Bluetooth, search for and connect to the corresponding device's Bluetooth. Secondly, configure the network for the device by turning on Hotspot [set the Hotspot name and password as simple as possible] and entering the Hotspot information. Click on Configure, and the device will automatically connect to the phone's Hotspot.

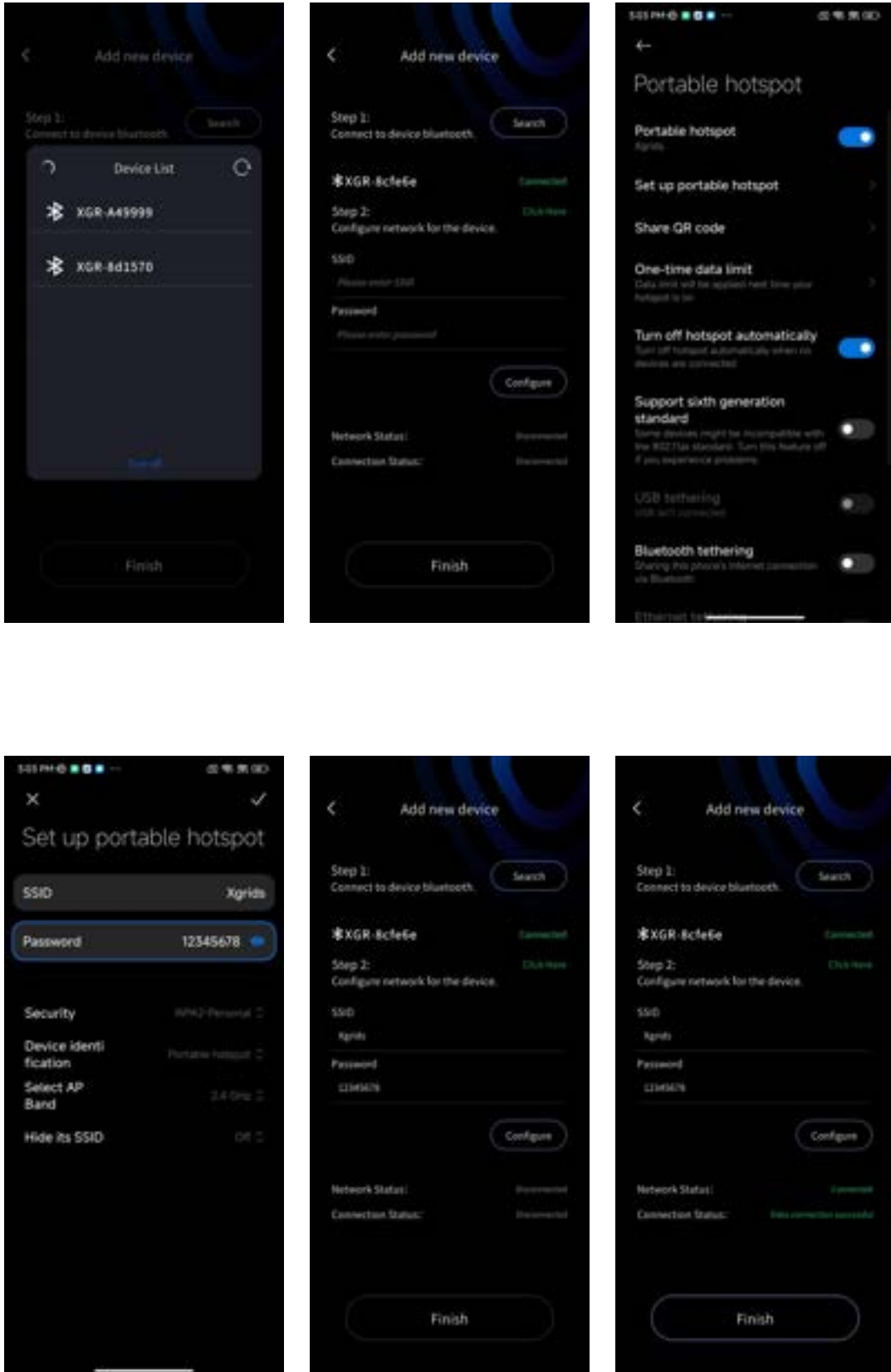

When Network Status becomes "Connected" and Connection Status reads "Data connection successful", click "Finish". You will be directed back to the home page where

the basic information of the connected device is shown.

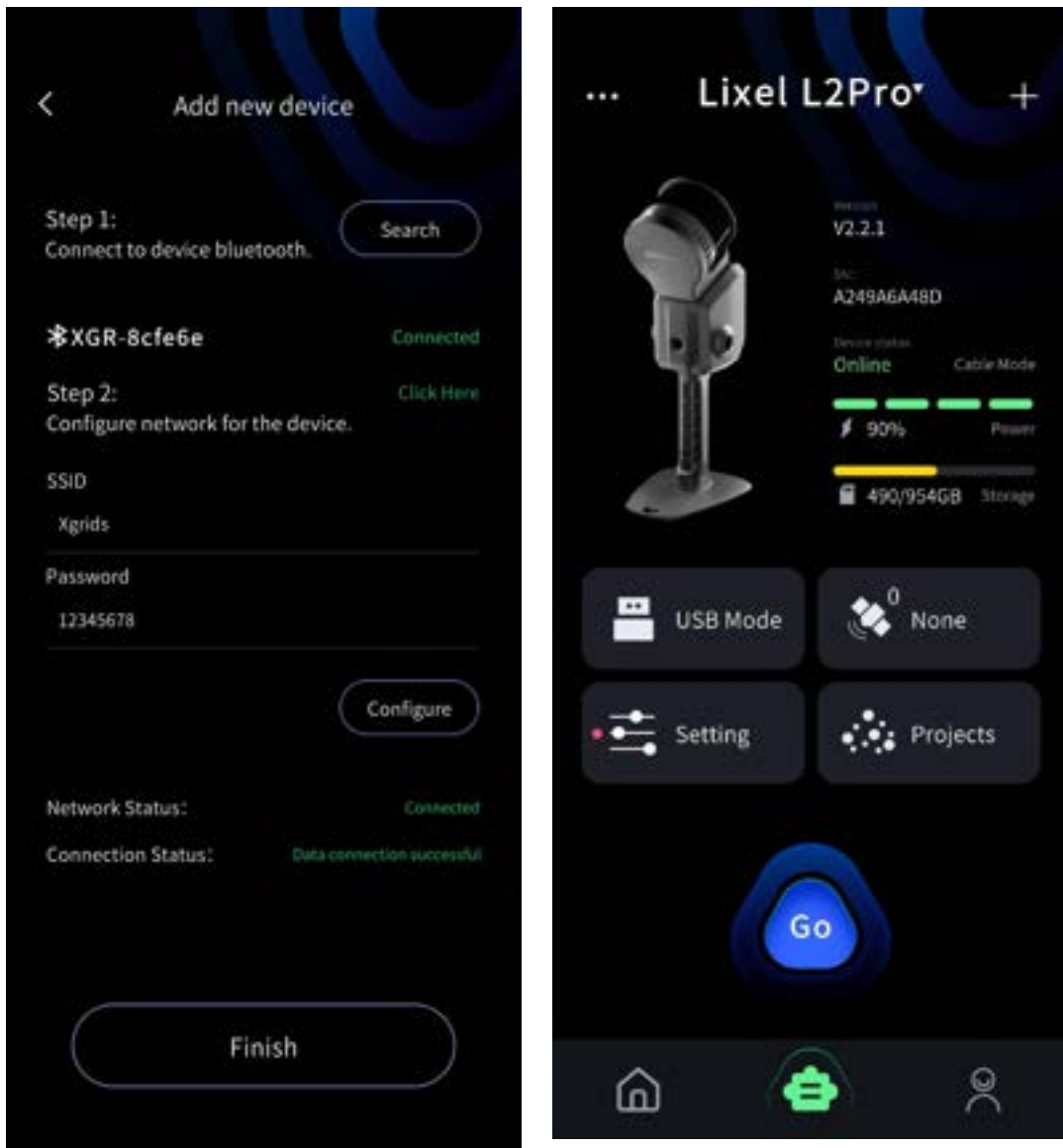

Bridge Mode (connecting the scanner and cell phone to the same WiFi network for data transmission) : Note: In this mode, if the scanner and the mobile phone move out of the WiFi network range, data transmission will be interrupted, but the devices will continue to record normally.

Click the plus sign in the upper right corner of the interface; select Bridge Mode; enter the interface, and then refer to the following steps.

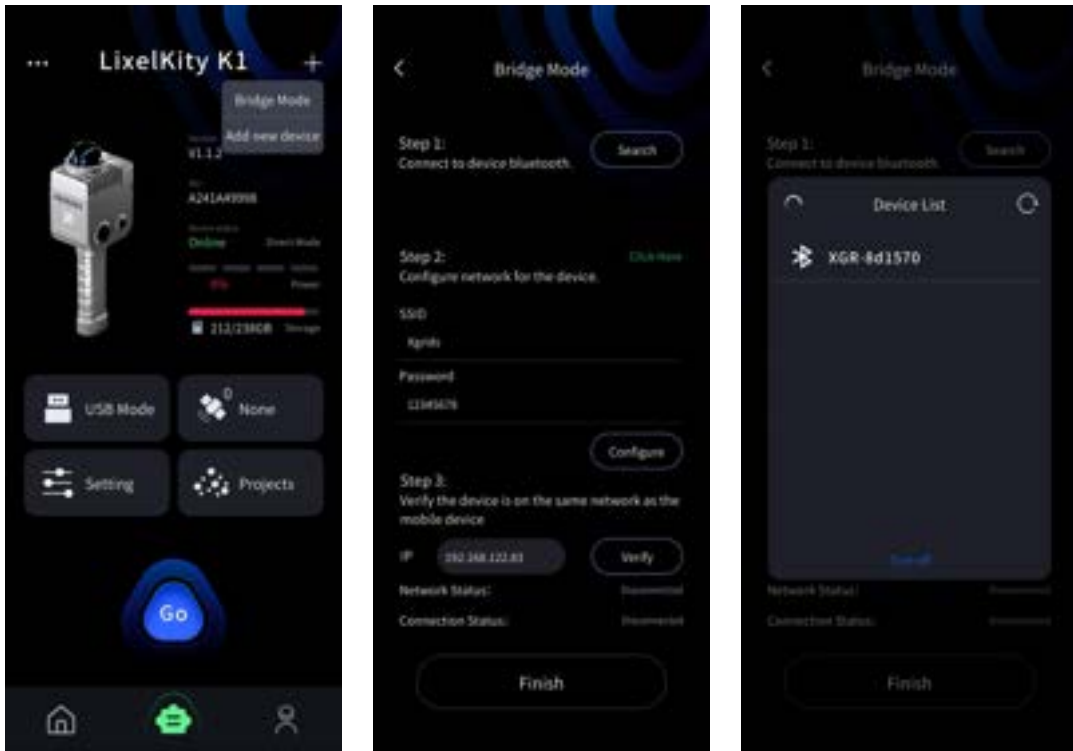

First, search and connect to the device's Bluetooth. Secondly, configure and verify the WiFi network. Here, SSID and password should be WiFi name and WiFi password. Once you have configured the WiFi information, IP will be loaded in automatically. After successfully connected, click "Finish" to view the device's basic information.

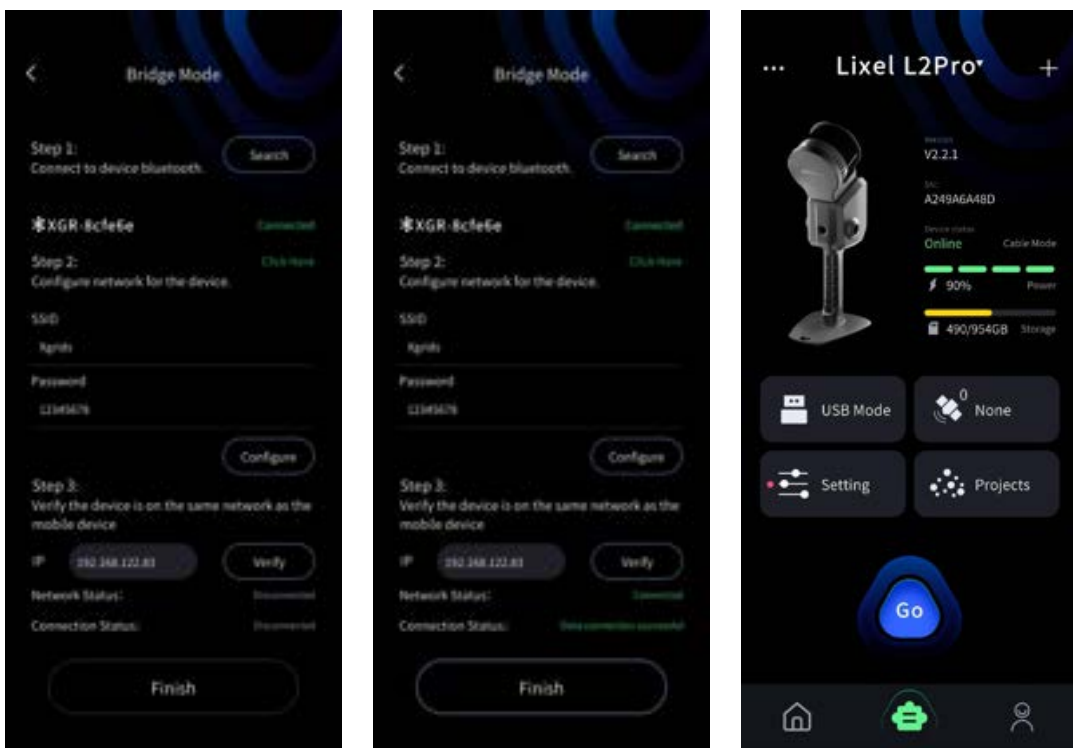

Quick Connect Mode:

Firmware 3.1.1+: RTK and activation supported. Remote transmission unavailable.

Firmware <3.1.0: Activation only.

Restart device to restore to default mode.

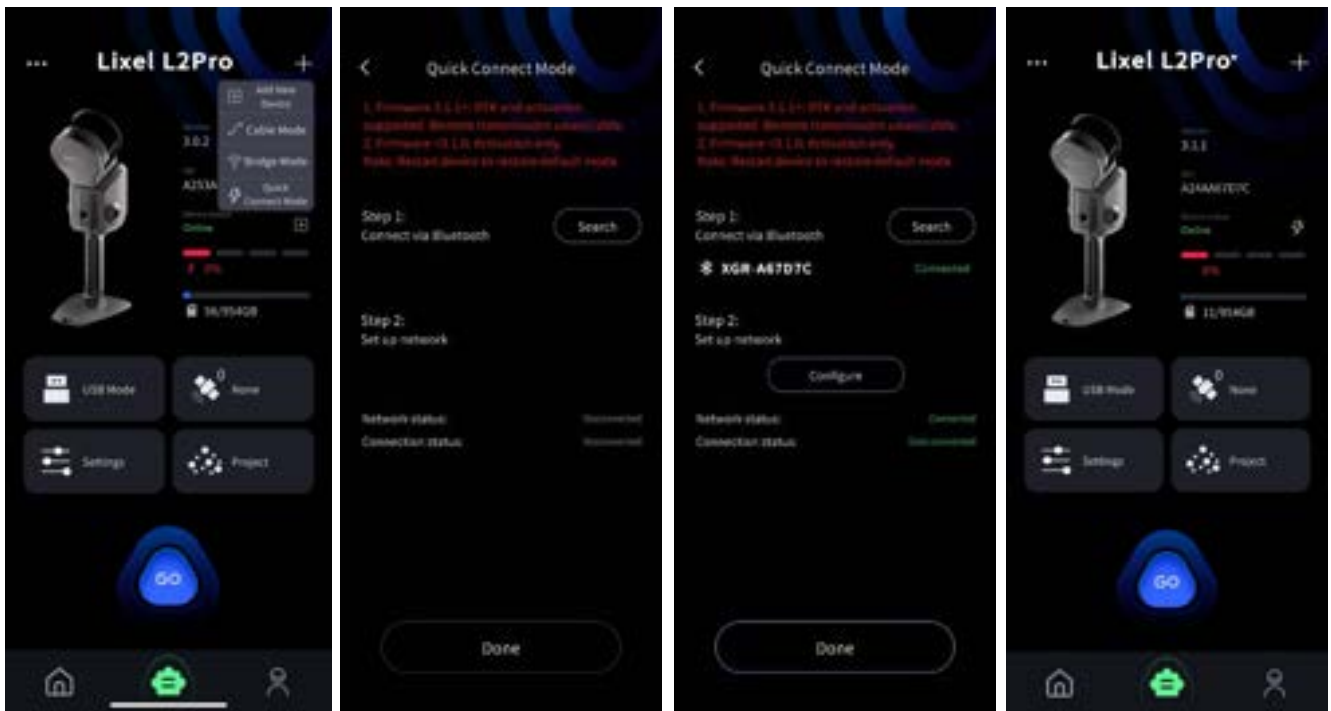

**IOS version**

Quick Connect Mode:

Firmware 3.2.1+ & LixelGO 1.3.0 : Use Quick Connect Mode by default

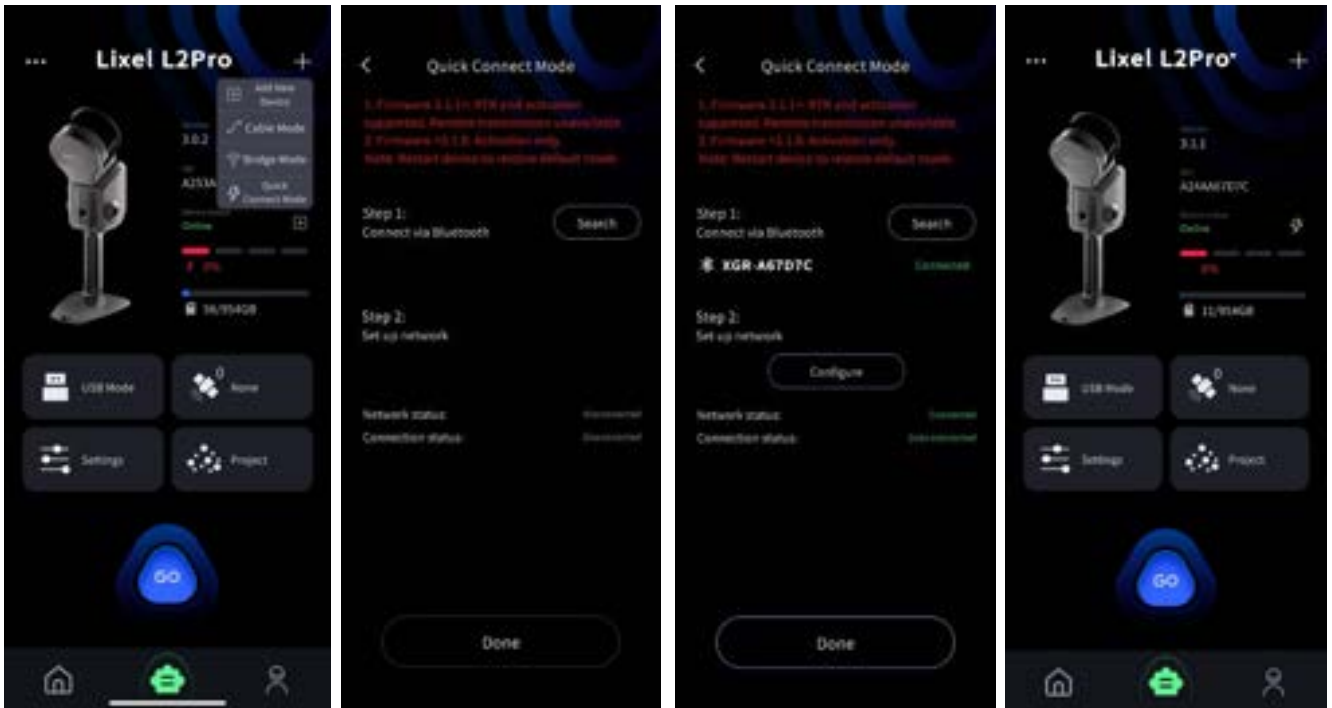

Before using the app, you need to do some settings for your iPhone first. Click on "Settings" to enter "General," then go to "About." Modify the "Name" field to contain only English characters without using any spaces or special characters. This "Name" is used as the SSID for the phone.

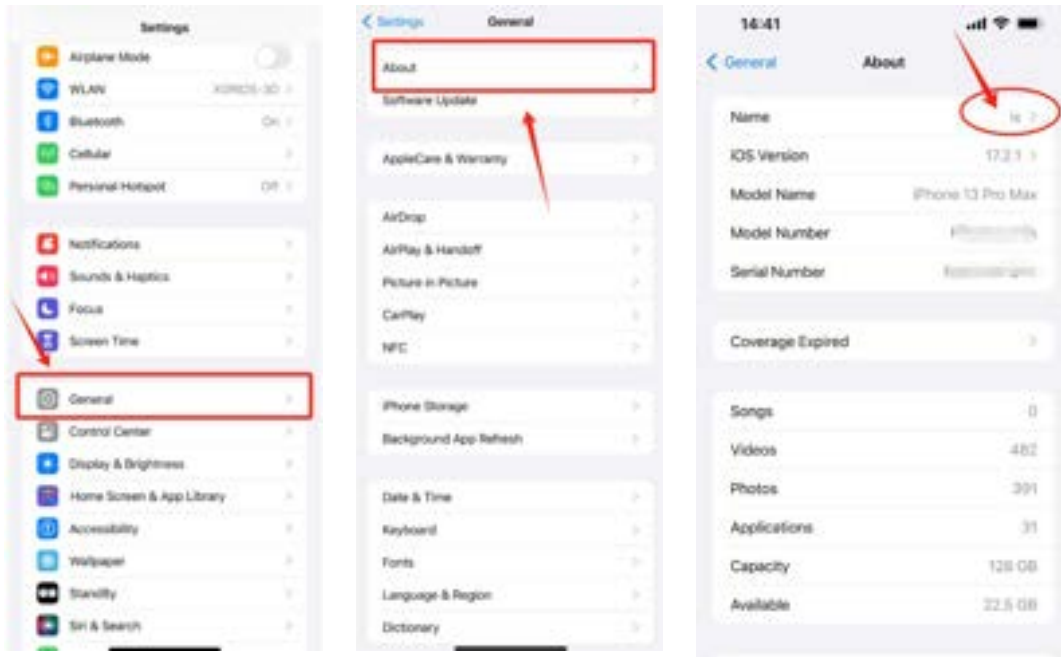

Press and hold the power button to turn on the device, and the indicator light will change from flashing blue to green for successful startup.

Direct Connect Mode: Click Add a new device; confirm that you have turned on your Bluetooth and Hotspot, and then follow the following steps.

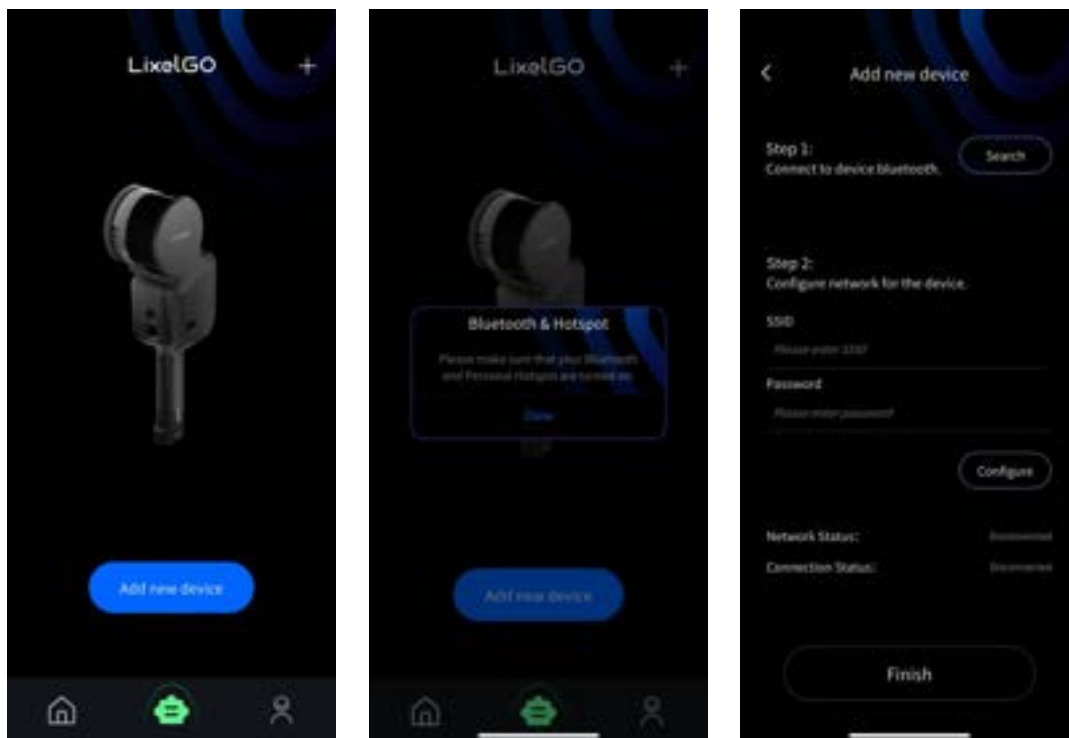

First Time Connection:

Click "Allow" for notifications.

Select "WLAN & Cellular" when choosing wireless data usage.

Click "Allow" for Bluetooth.

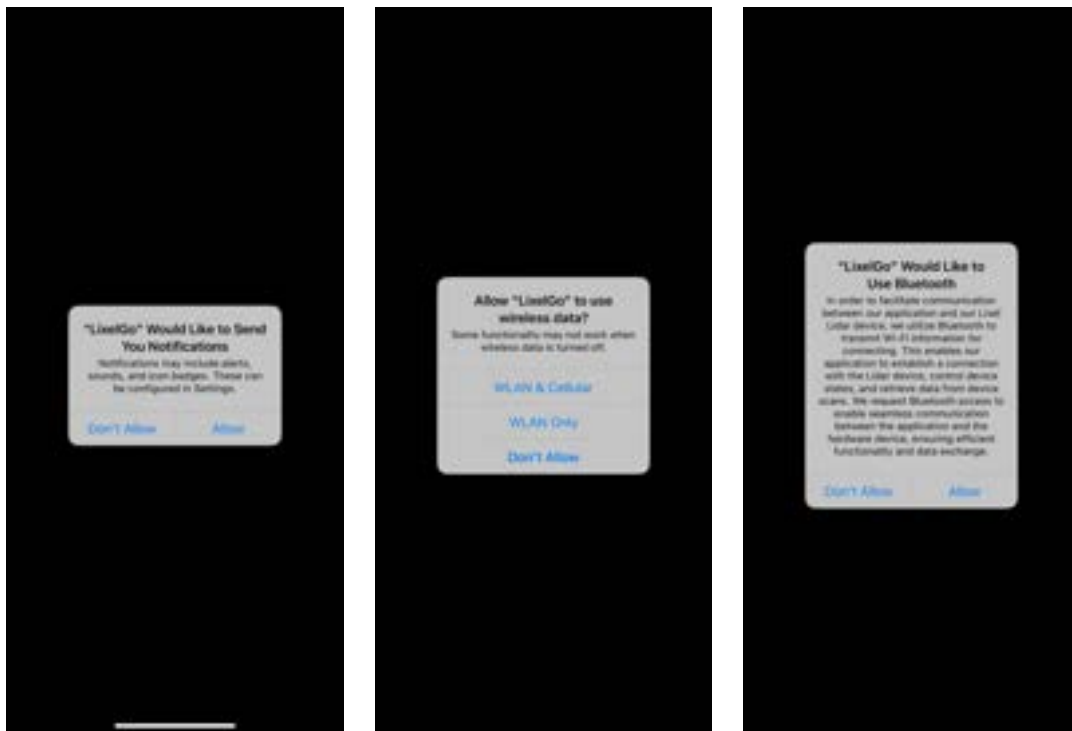

Turn on the phone's Bluetooth, and search for and connect to the corresponding device's Bluetooth. Then, configure the network for the device. Enter the device name of your iPhone and the password of your Hotspot. Double check that you have set the password as simple as possible. Click on Configure, read the tips carefully.

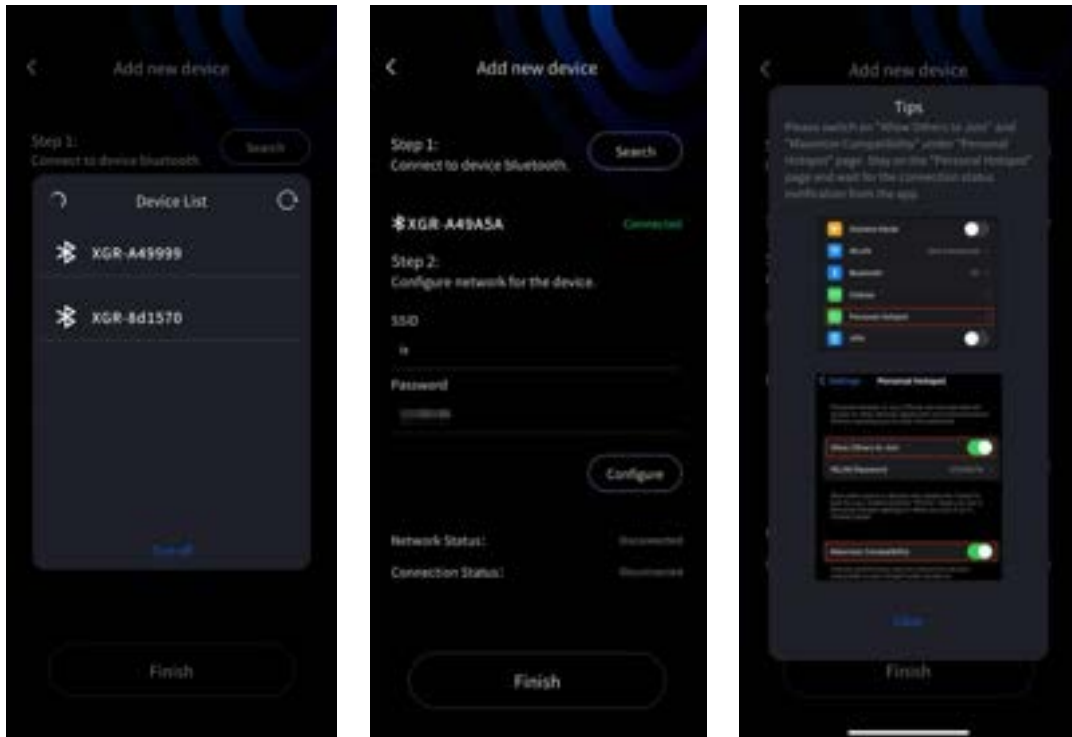

When enabling the Hotspot, cellular data (mobile network) must be turned on. (Do not switch on or turn off WiFi when setting up the Hotspot, as changing the Wi-Fi connection status will affect your Hotspot status)

Ensure that the "Allow Others to Join" toggle is switched on to allow devices to connect. The Hotspot selection must be set to maximum compatibility for successful connection.

Most importantly, stay on the "Personal Hotspot" page and pay attention to the notification messages. Only after you see "Data Connection Successful!" should you go back to the LixelGo app.

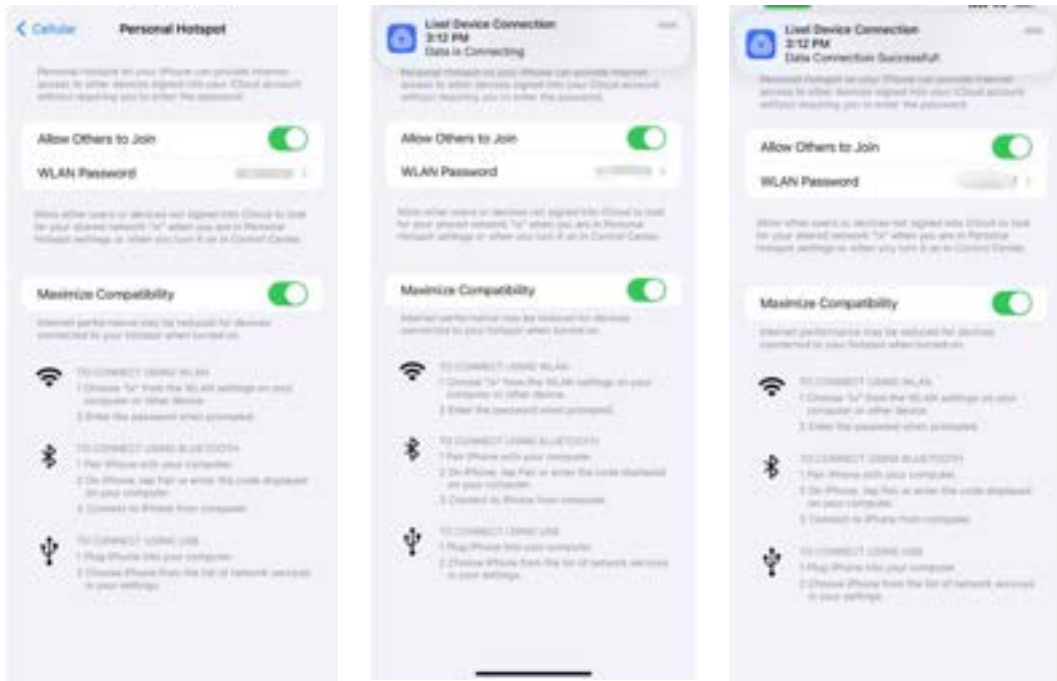

During the first connection, data connection may fail due to permission reasons. After returning to LixelGo, clicking "Configure" will prompt the permission dialog again. Selecting "Allow" will immediately establish a successful connection.

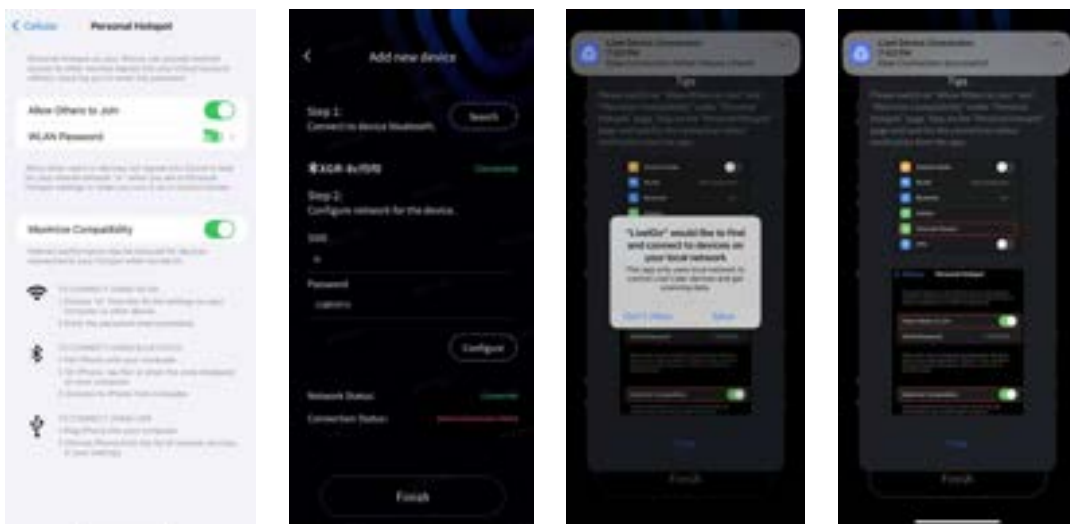

When both the network connection status and data connection status are displayed as successful, click "Finish" to view the basic information of the currently connected device.

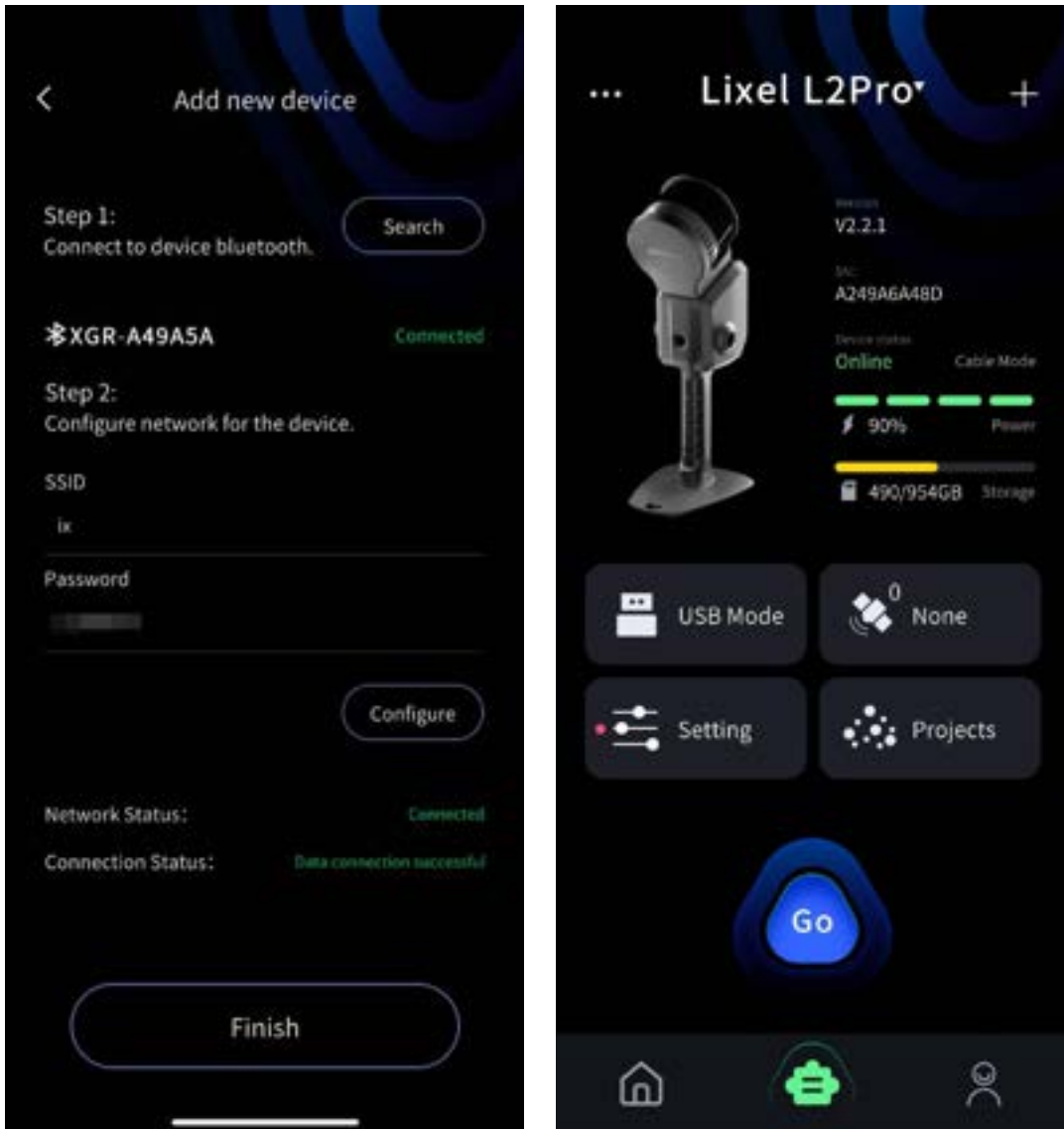

Bridge Mode (connecting the scanner and cell phone to the same WiFi network for data transmission) : Note: In this mode, if the scanner and the mobile phone move out of the WiFi network range, data transmission will be interrupted, but the devices will continue to record normally.

Click the plus sign in the upper right corner of the interface; select Bridge Mode; enter the interface, and then refer to the following steps.

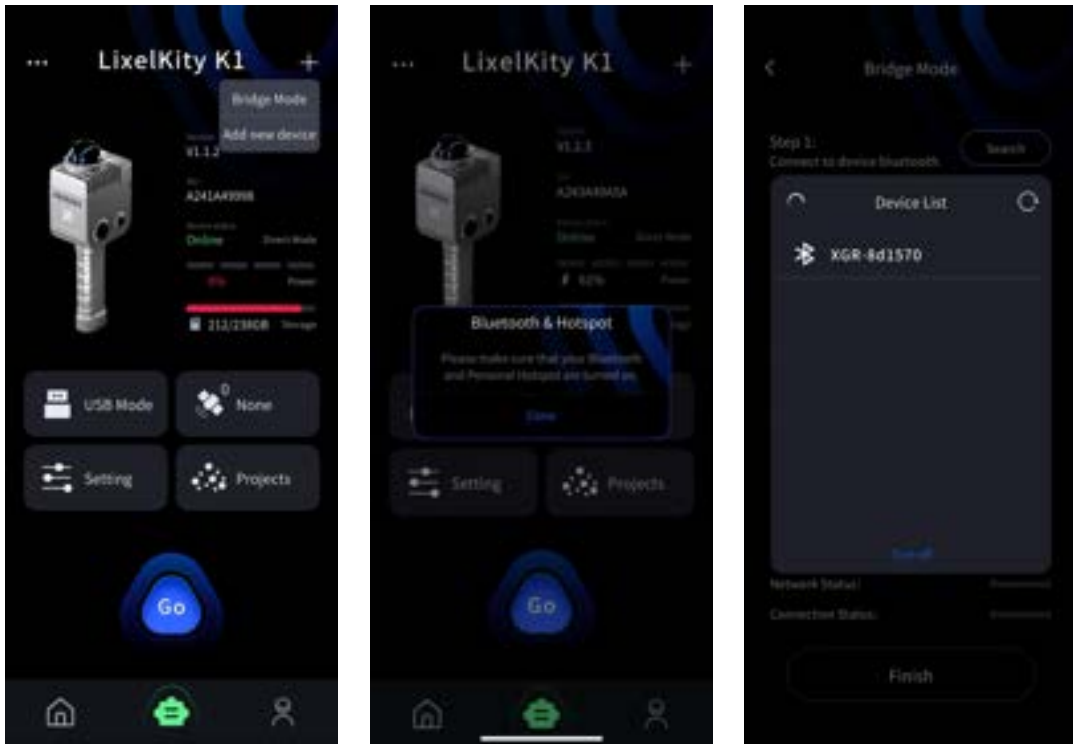

First, search and connect to the device's Bluetooth. Secondly, configure and verify the WiFi network. Here, SSID and password should be WiFi name and WiFi password. Once you have configured the WiFi information, IP will be loaded in automatically. After successfully connected, click "Finish" to view the device's basic information.

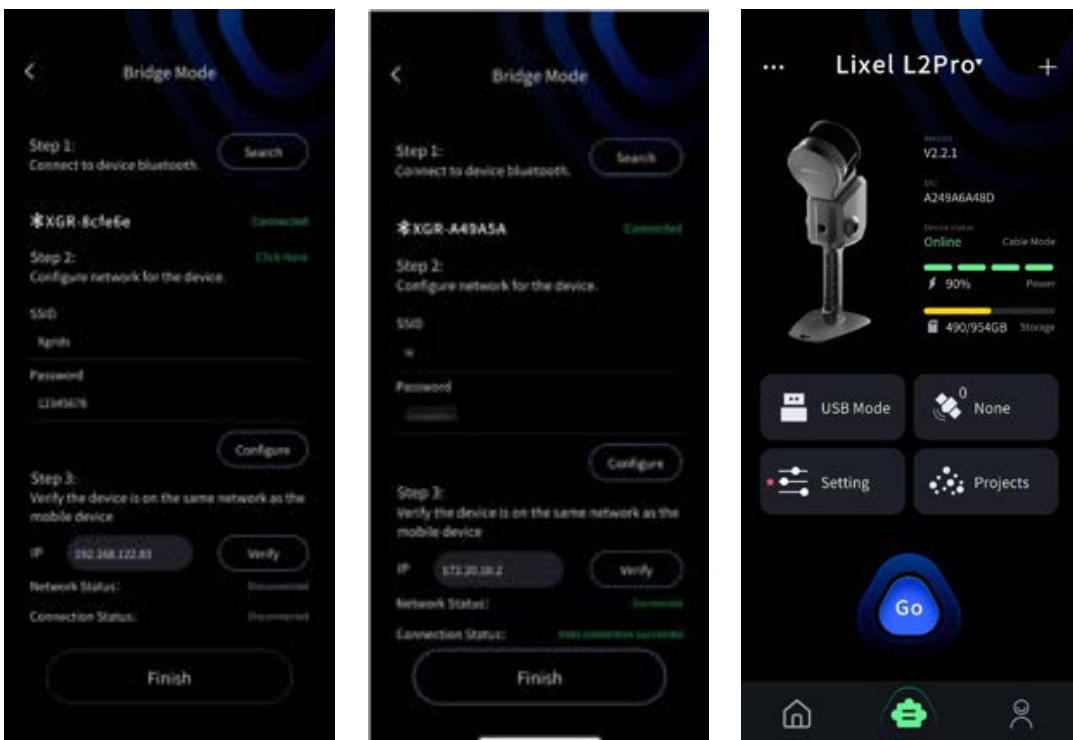

Quick Connect Mode:

Firmware 3.1.1+: RTK and activation supported. Remote transmission unavailable.

Firmware <3.1.0: Activation only.

Restart device to restore to default mode.

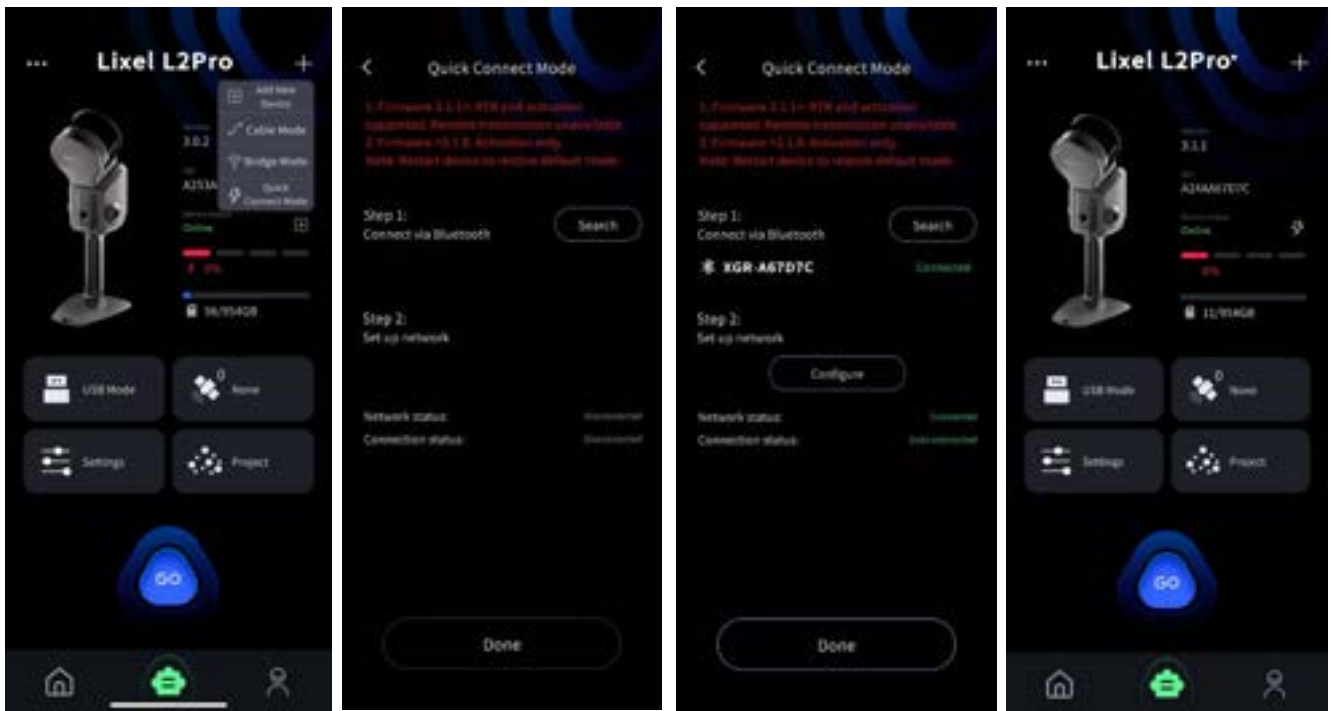

## 5. Device Management

In the device interface, click and pull down the device name at the top of the screen to manage connected devices. Click Remove Device to remove the connection to the device.

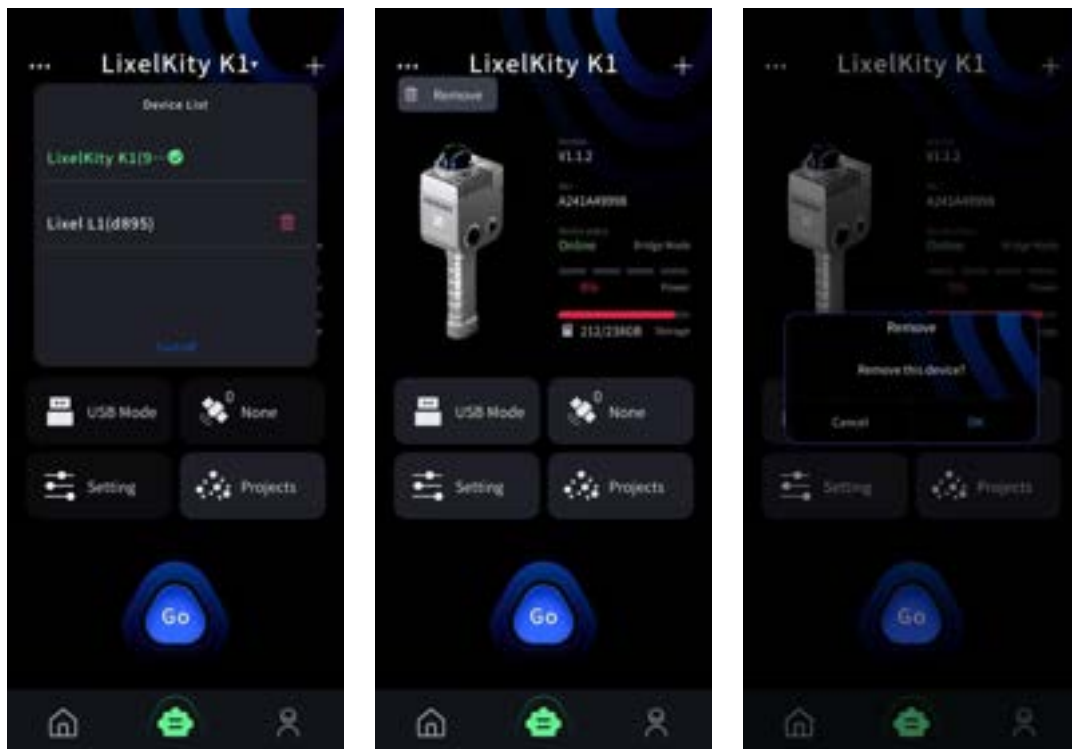

## 6. Device Activation

Click "Go", and confirm the activation and binding of the device.



## 4 Scan

### 4.1 Connected the device

Click "Go" to enter the scanning standby page.

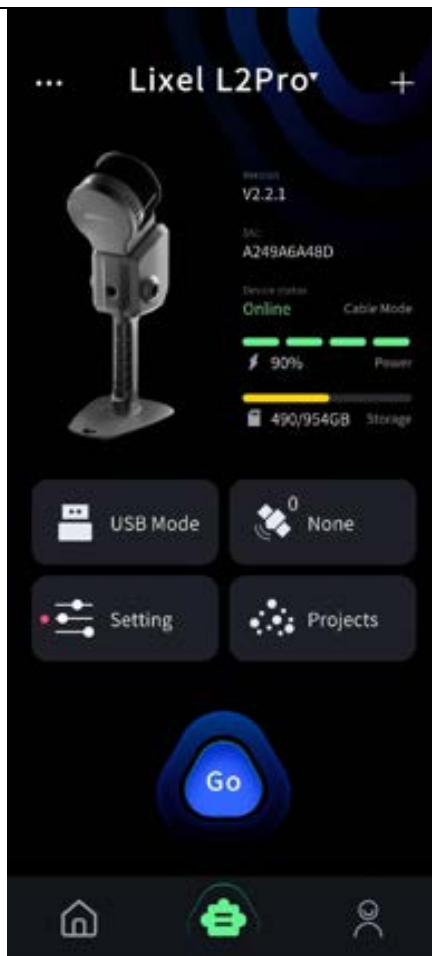

The device undergoes time calibration before leaving the factory, but if it is stored for an extended period, the device's time may become inaccurate. The automatic synchronization switch in LixelGO is turned on by default, which will automatically synchronize the device's time with the time on your phone. Users can also customize the device's time settings through LixelGO. It is recommended that the device's time and time zone match the actual time and time zone of its location.

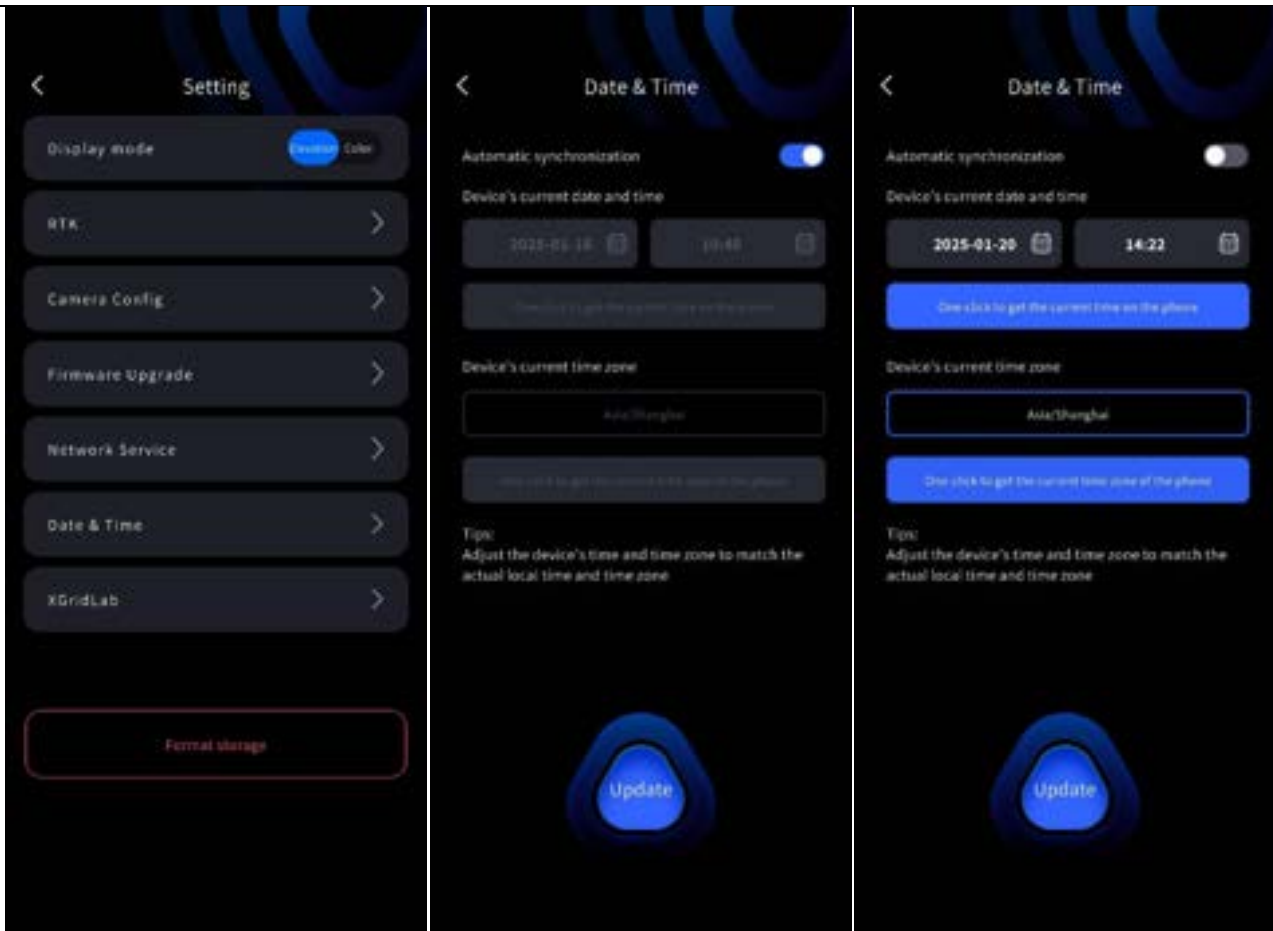

## 4.2 Scan Mode Settings (L2 Pro Only)

Click the red Record button on the right side of the screen and select the appropriate configuration.

Mount Type	Function Definition	Description
Handheld	Use in handheld mode.	LixelStudio will automatically read the mount mode, eliminating the need for manual selection during project processing.
Vehicle-Mounted	Use with XGRIDS vehicle-mounted accessories.	LixelStudio will automatically read the mount mode, eliminating the need for manual selection during project processing.

Drone	Use with XGRIDS drone accessories.	LixelStudio will automatically read the mount mode, eliminating the need for manual selection during project processing.
-------	------------------------------------	--------------------------------------------------------------------------------------------------------------------------

GNSS Type Settings	Function Definition	Description
Standard RTK	The device will use parameters for standard RTK.	On the startup page, correctly select the RTK type mounted on the device.
Survey RTK	The device will use parameters for surveying RTK.	On the startup page, correctly select the RTK type mounted on the device.
Aerial RTK	The device will use parameters for XGRIDS drone accessories.	On the startup page, correctly select the RTK type mounted on the device.

Remote Transmission	Function Definition	Description
Remote Transmission Switch	Displays whether remote transmission is enabled.	This status is only visible for devices configured with XGRIDS Cloud service codes.  Since remote transmission consumes network traffic, the remote transmission switch status is visible on

the startup page.

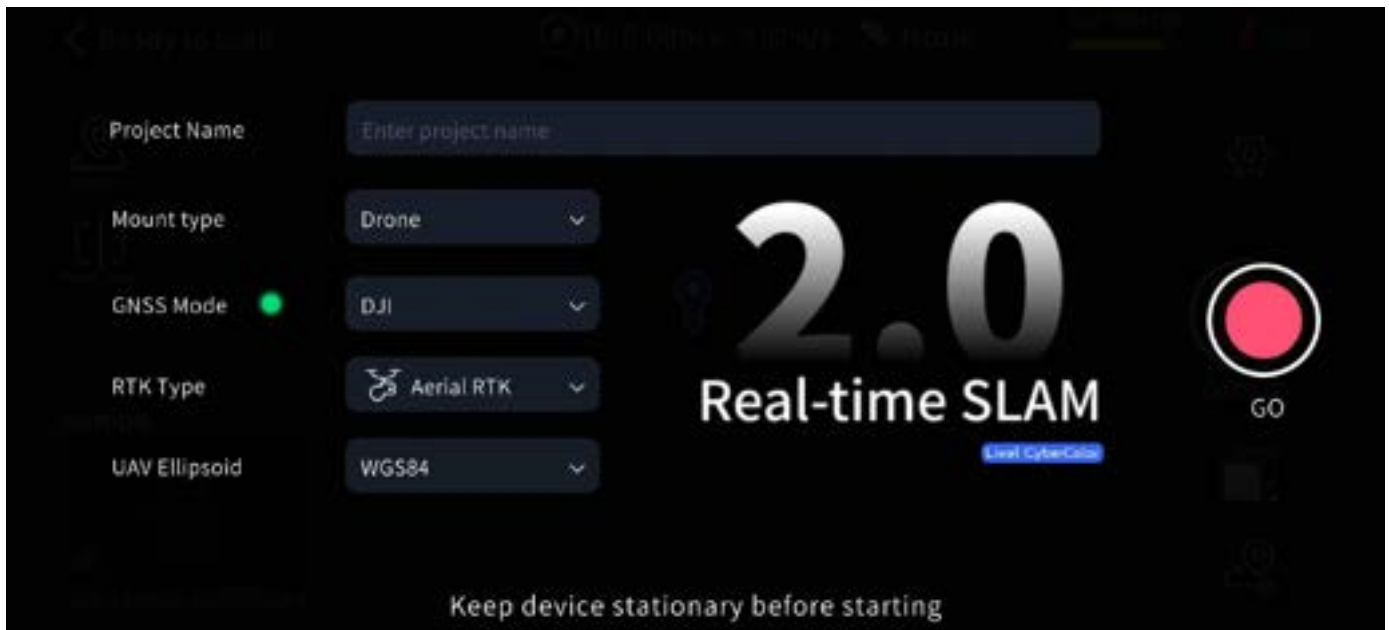

When initiating a scan, an input field for the project name will be displayed on the startup page, and the input field supports multiple languages. If you enter "Parking Lot B2F" and start the scan, after the scan is completed, you will see the project folder named: "Parking\_Lot\_B2F\_2025-01-15-1622026," where "2025-01-15-1622026" represents the scan time. If no project name is entered, the project folder will be named: "default\_2025-01-15-1622026."

### 4.3 Start Scanning

After the scanning mode selection is completed, the LiDAR scanner will start. The indicator light will turn green and will flash quickly. The app will prompt that static initialization has started, and then it will start a 15s static initialization countdown. During this process, ensure that the device is always in a stable state. After the countdown ends and a pop-up window prompts that static initialization is complete, close the pop-up window, pick up the device, walk around, and start scanning according to the planned route.

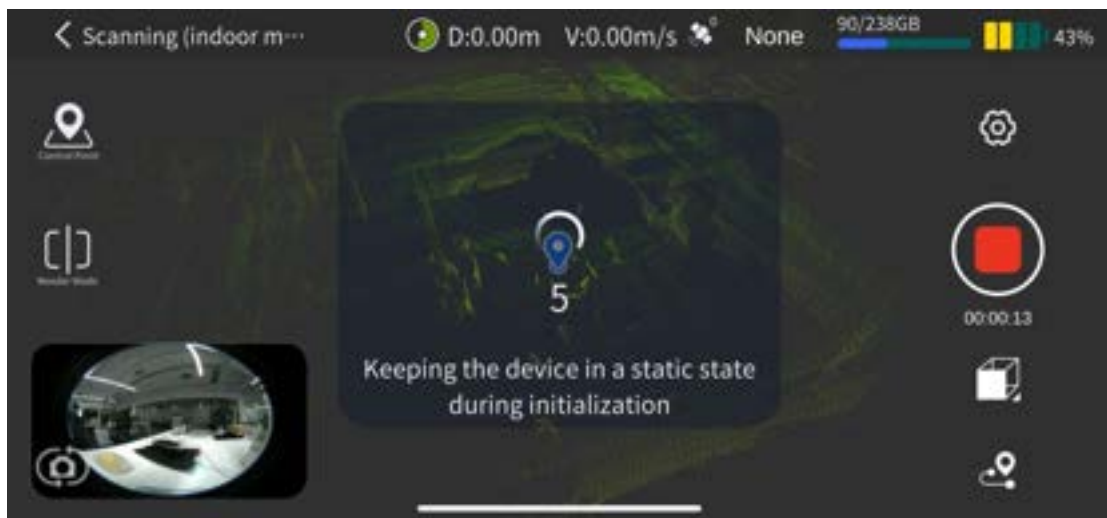
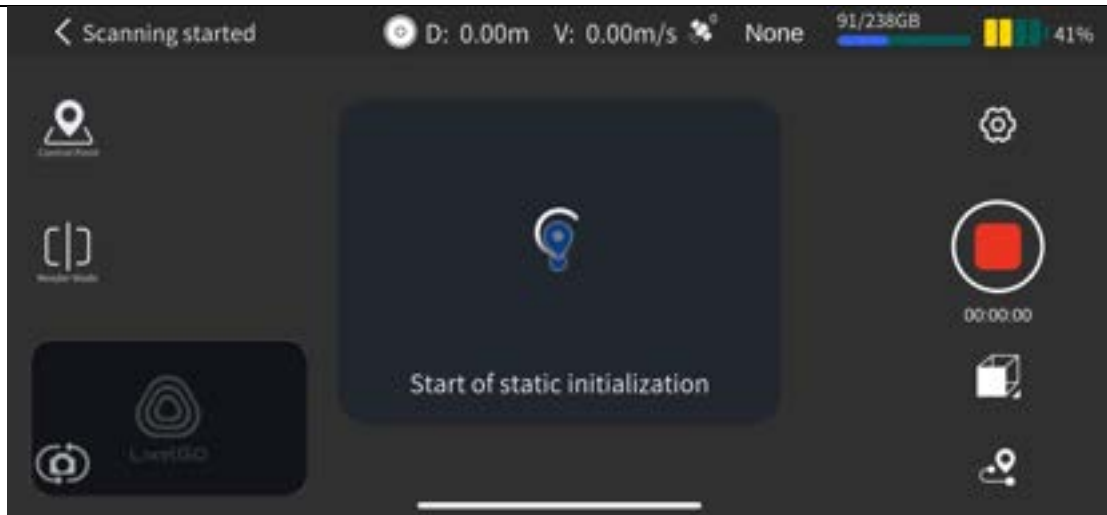

## 4.4 Rendering Mode

Click the "Render Mode" button on the left side of the screen to modify the real-time point cloud rendering method. Currently, there is one mode available: "EL" - elevation.

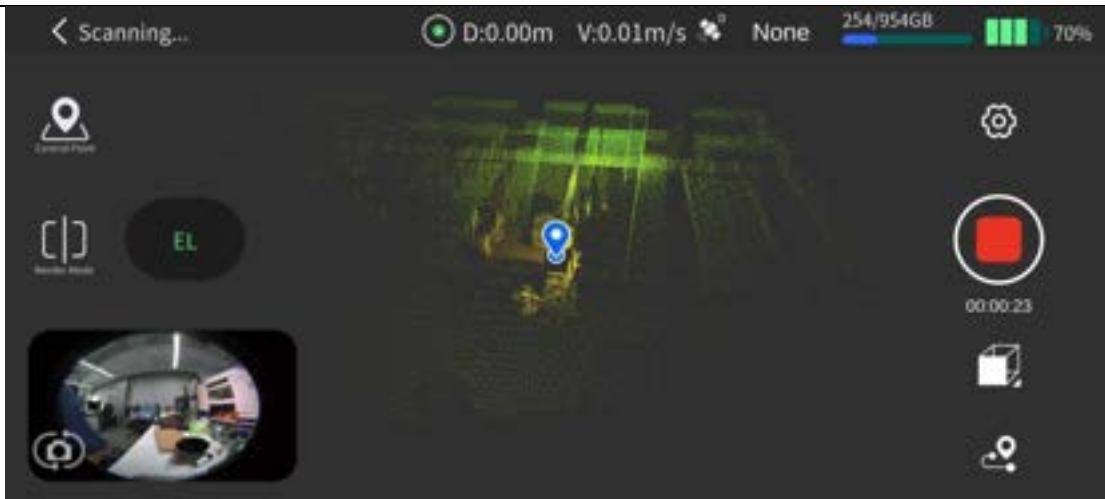

## 4.5 Stop Scanning

Click the red Record button on the right side of the screen. After confirming, the device's green light will flash quickly. The indicator light will turn green and stay on after the scanning is saved completely. Then you can shut down the device or start the second scan.

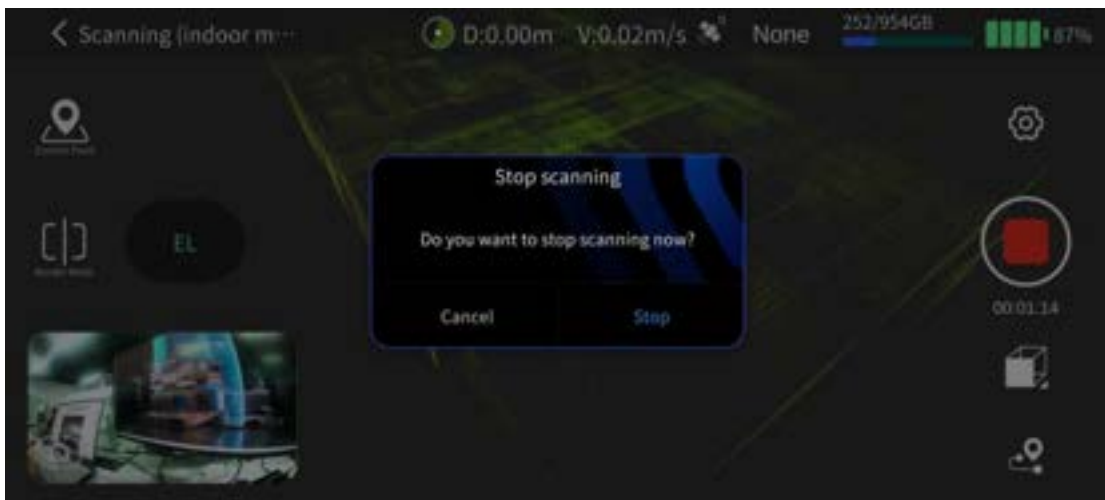

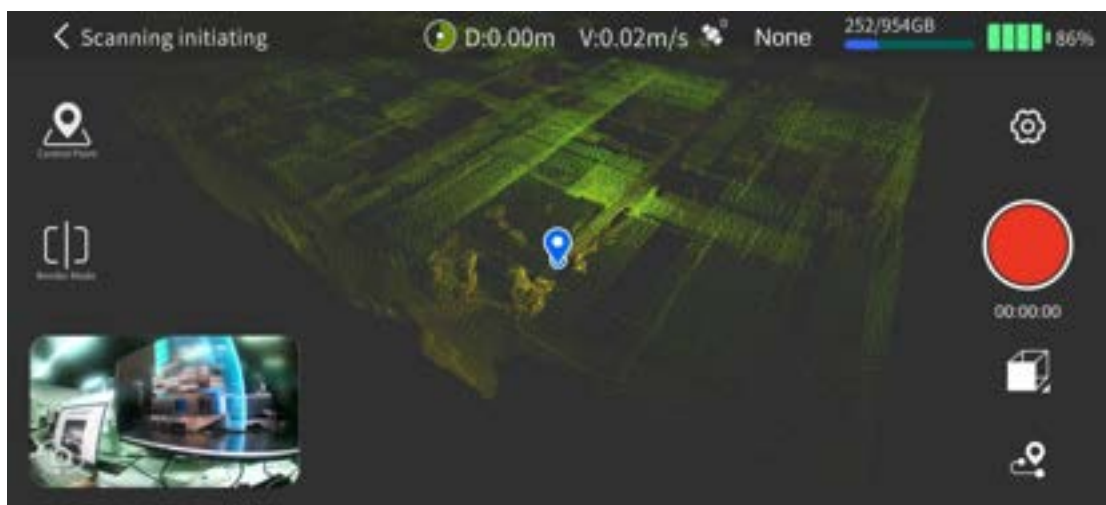
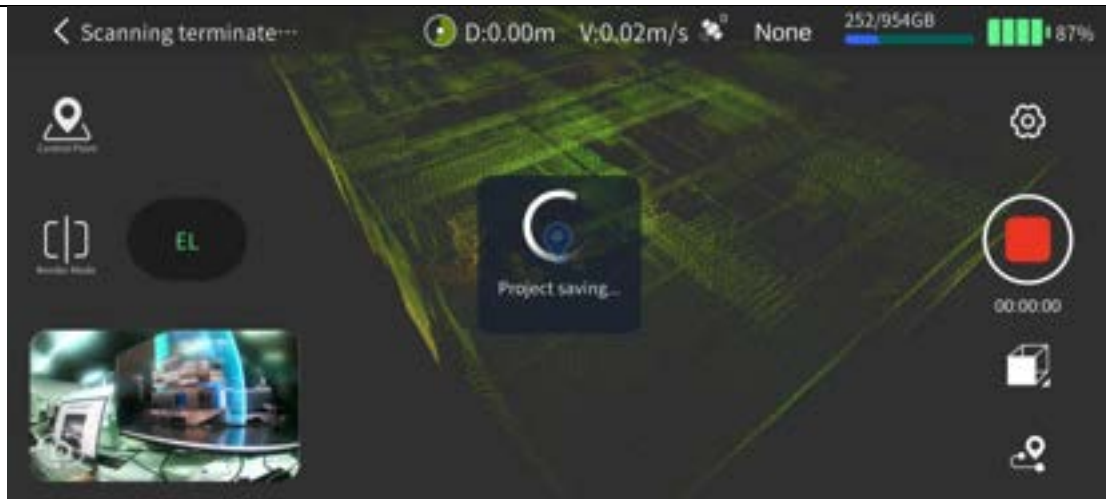

### 4.6 View Model

After scanning, you can view the scanned model details in LixelGO.  
(Firmware v3.2.1+ required, LixelGO v1.3.0+ required)

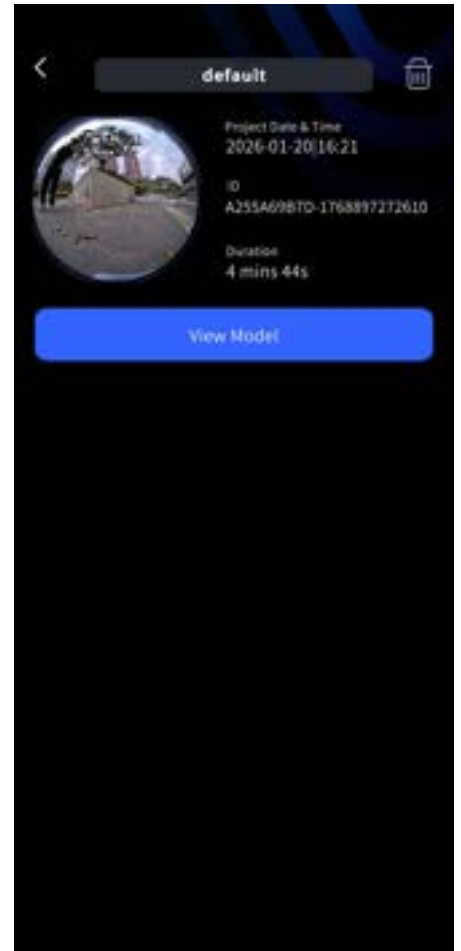
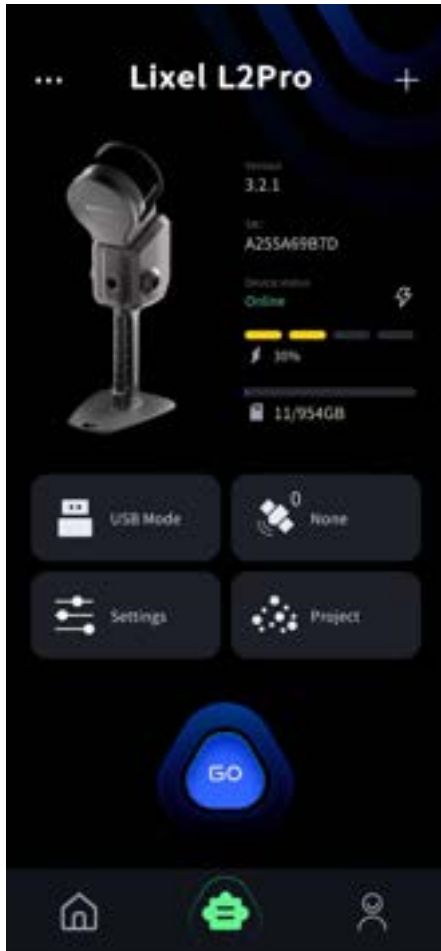

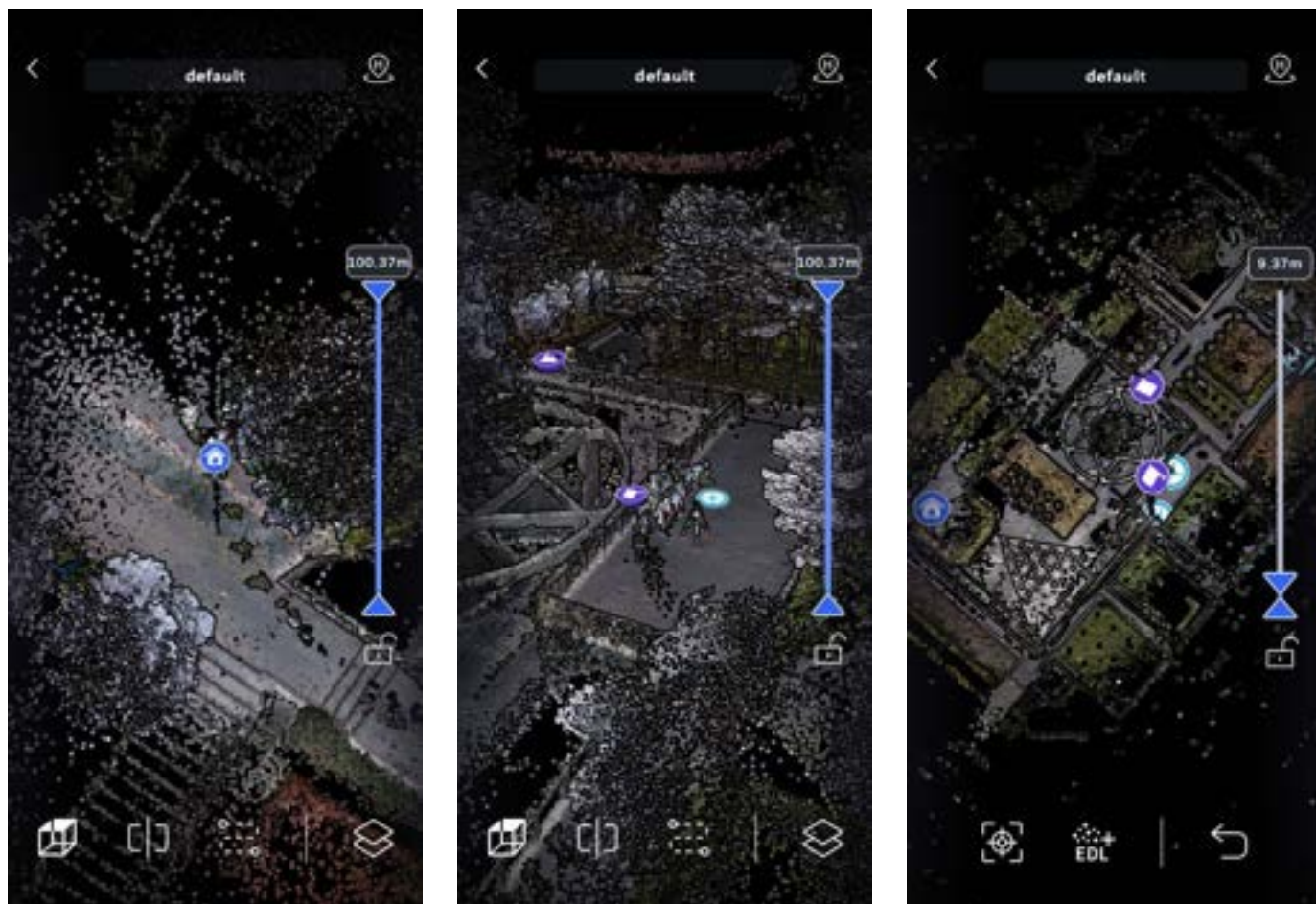

## 4.7 Downloading Scanned Data

Turn on the device, set the device to USB mode in the app, and then use a Type-C cable to connect the device to the computer.

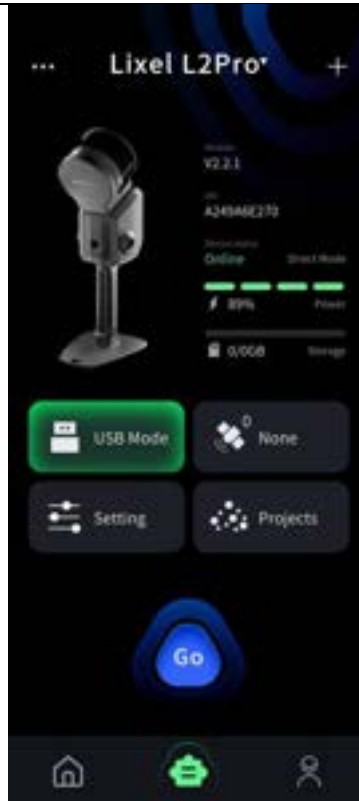





In the model file in the directory of USB disk mode, select the corresponding project file  
 And you can copy it to the appropriate directory of the computer. The project files name  
 after the time of scan starting: ProjectName-year-month-day-specific time

default_2025-01-16-151347	2025/1/16 15:13	文件夹
default_2025-01-19-122200	2025/1/19 12:22	文件夹
default_2025-01-20-151747	2025/1/20 15:17	文件夹
packing_lot_B2F_2025-01-20-155803	2025/1/20 15:58	文件夹
SMBU_2025-01-19-112340	2025/1/19 11:23	文件夹

## 4.8 Data Project File Structure

.hbc is the raw sensor data recorded by the device.

 external_data	2025/6/6 15:28
 project_data	2025/6/6 15:28
 2025-06-06-152838.xbin	2025/6/6 15:30
 map.las	2025/6/6 15:30

File or folder name	Files in the subdirectory	Introduction
xxx.xbin	-	raw sensor data recorded by the device.
map.las	-	the point cloud data directly output by the scanning device in real time.
project_data	control_points.csv	Control point information when using the app to add control points.
	gnss.csv	A file that records GNSS information when using RTK.
	poses.csv	Record the trajectory file during the scanning process.
	model	In-app model preview file
	photo	Camera image captured when adding a control point
	preview_photo.jpg	Preview photo
	measure_points.csv	Measure point information when using the app to add measure points.
	project.json	Record device-related information.
	log	The log folder records the relevant log information of the device.
external_data	-	This folder is empty when the data is initially copied from the handheld device. It is mainly used to copy and store external file

		data required for post-processing in LixelStudio, such as video files of external panoramic cameras and gnss.csv files after coordinate conversion.
--	--	-----------------------------------------------------------------------------------------------------------------------------------------------------

Please note: The direct point cloud data is downsampled. If you need complete point cloud data, please use LixelStudio software for post-processing.

## 4.9 XGRIDS LAB

This feature is part of the XGRIDS LAB. XGRIDS Innovation will place specific experimental functions into the XGRIDS LAB for testing in special environments.

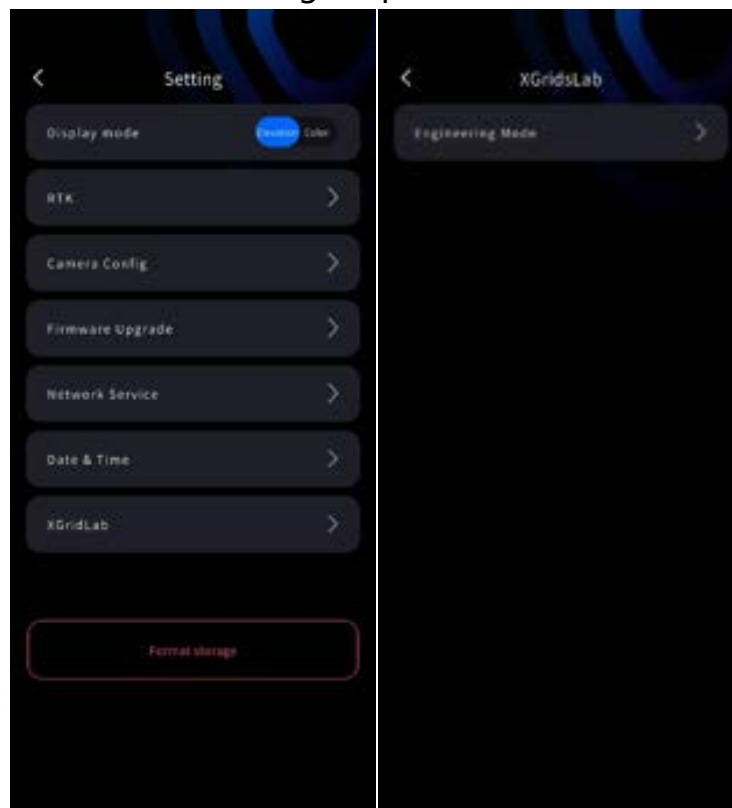

# 5 Acquire Point Cloud Data with Absolute Coordinate

## 5.1 Through Existing Ground Control Points (GCP)

You can achieve coordinate conversion through the existing Ground Control Points (GCP) you marked during the scan, by which the accuracy of the point cloud data can be optimized as well.

Note: The number of control points in the scanning area is determined according to the accuracy requirements. And the layout of control points should be evenly distributed. To ensure subsequent coordinate conversion to be successful, at least 3 or more control points reasonably distributed are required for a single scan. The more high-precision control points covered by scanning, and the more evenly distributed, the higher the accuracy will be. Control points should not be located on the same line.

### 1. Scanner Installation

#### Equipment List

Lixel L2 Pro Handheld scanner, battery, control point Base. The installation diagram is as follows.

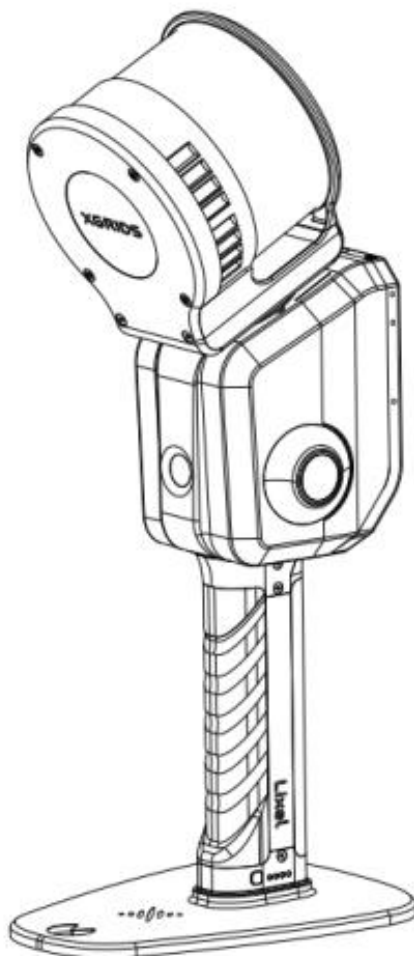

## 2. Field Work: Scanning

### Field Survey and Planning

If there is a corresponding topographic map of the scanning area, the control points can be designed according to the map, and the on-site inspection and design can be carried out synchronously. If there is no corresponding topographic map, the design will be carried out according to the on-site environment.

The distribution of control points should be as reasonable as possible, which means evenly distributed in the scanning area. And the distance between control points should be within 100 meters.

According to the distribution of control points and scanning environment, plan a reasonable scanning route.

### Start Scanning

Turn on the scanner, and start scanning through the LixelGO App or the button on the device. For specific steps, please refer to the Scanning Workflow.

### Mark Ground Control Points (GCP) During the Scan

When scanning on the route across the areas covering the control point, align the sharp corner of the front end of the scanner control point base with the control point, and then click to add the control point in the App.

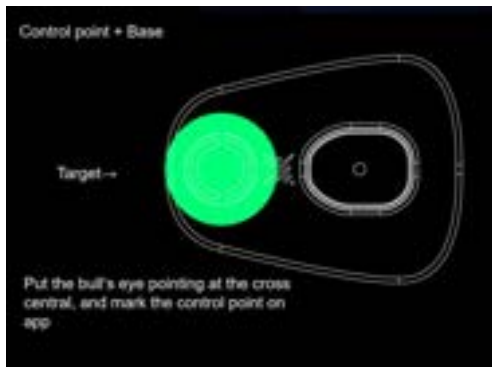

Click "Control Point Mode" on the left side of the screen.

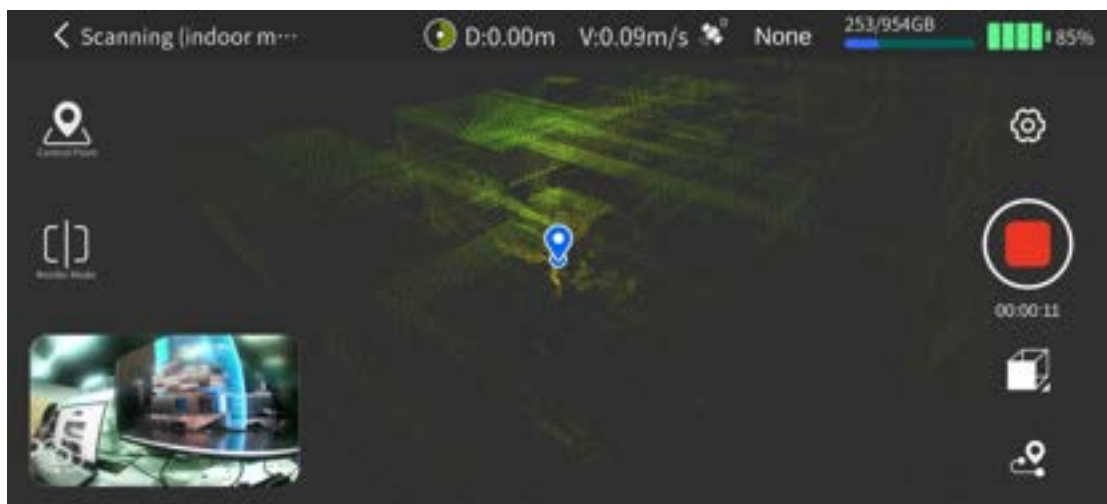

[GCP]Click "+" on the left side of the screen to add a control point.



Enter the control point number, then click OK, and the screen will pop up "The control point was added successfully", indicating that the control point was successfully marked.



Pay attention to the names and order of the control points marked on the app when

tapping. When you do the processing in LixelStudio later, you need to ensure that the file names of the imported control points correspond to the names of the control points marked during the scan.

If the name of the added control point is repeated, the app will pop up a reminder, please judge and and modify it according to the specific situation.

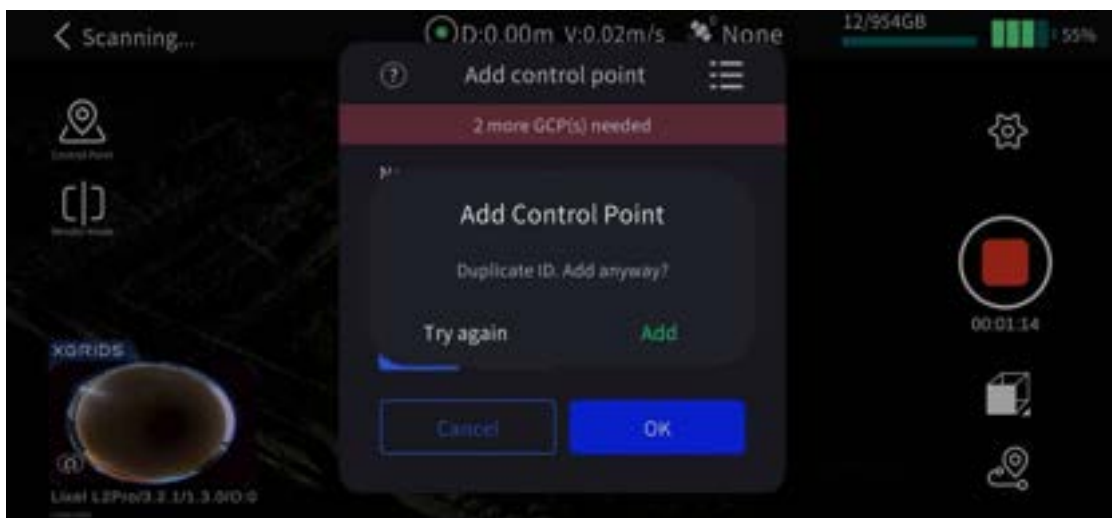
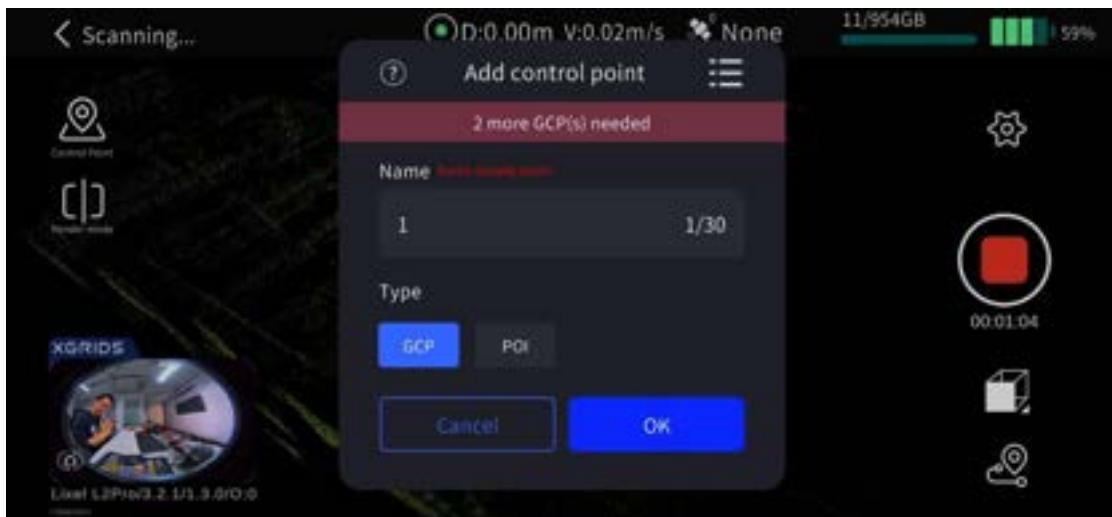

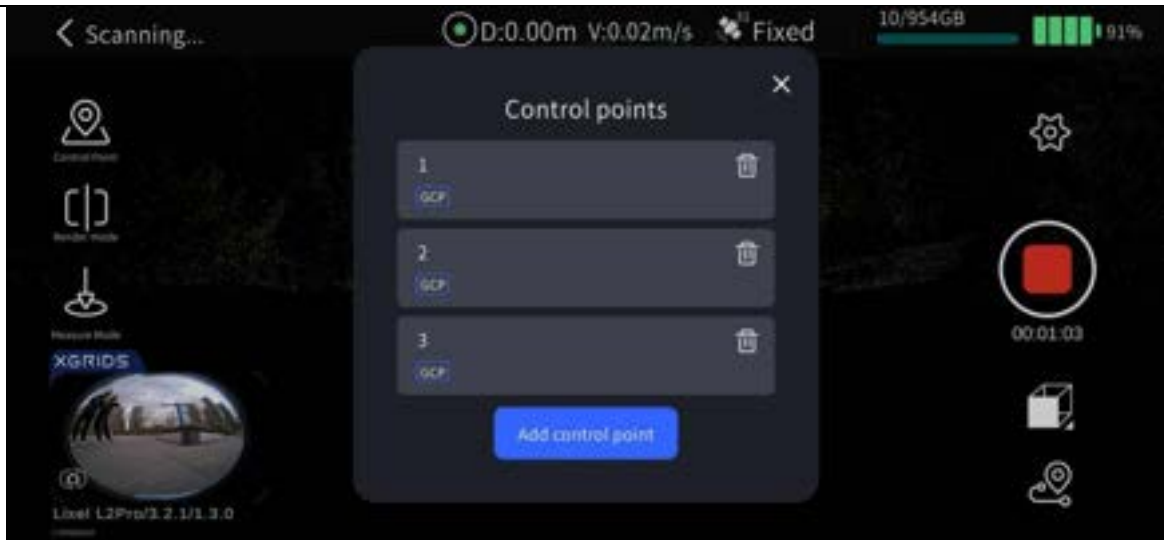

You can view the collected control points and delete control points in the "Control Point List" on the left side of the plane. Click the Delete button on the right side of the control point to delete the corresponding control point.

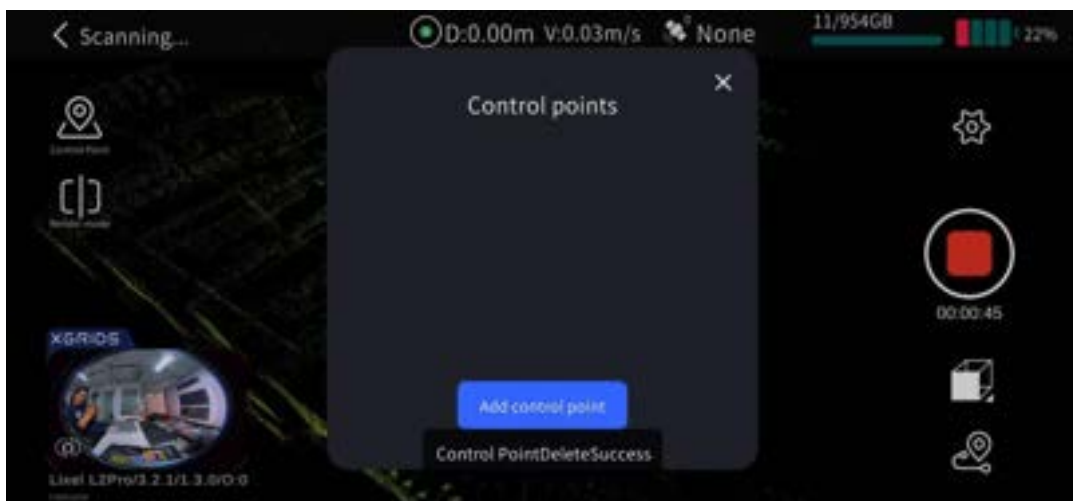
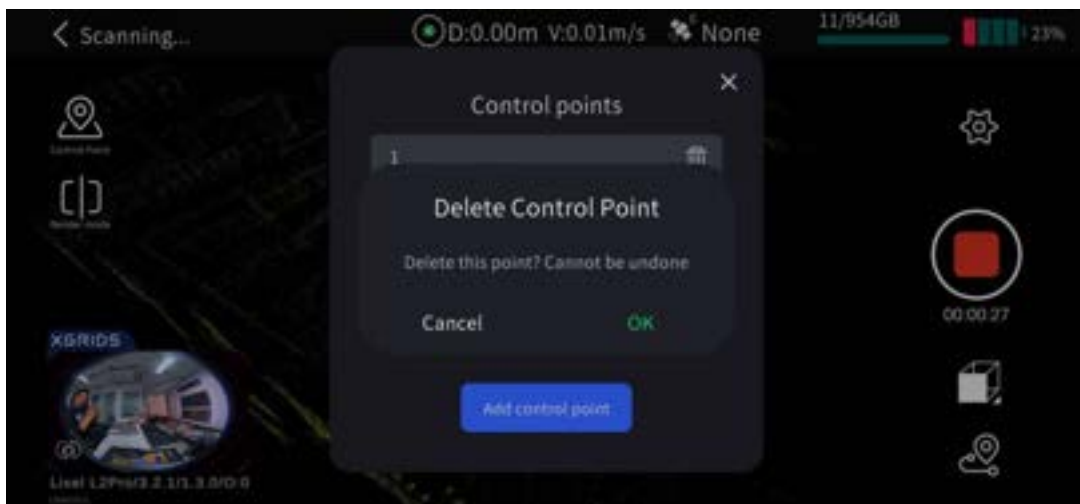

[POI] Click "+" on the left side of the screen to add POI.

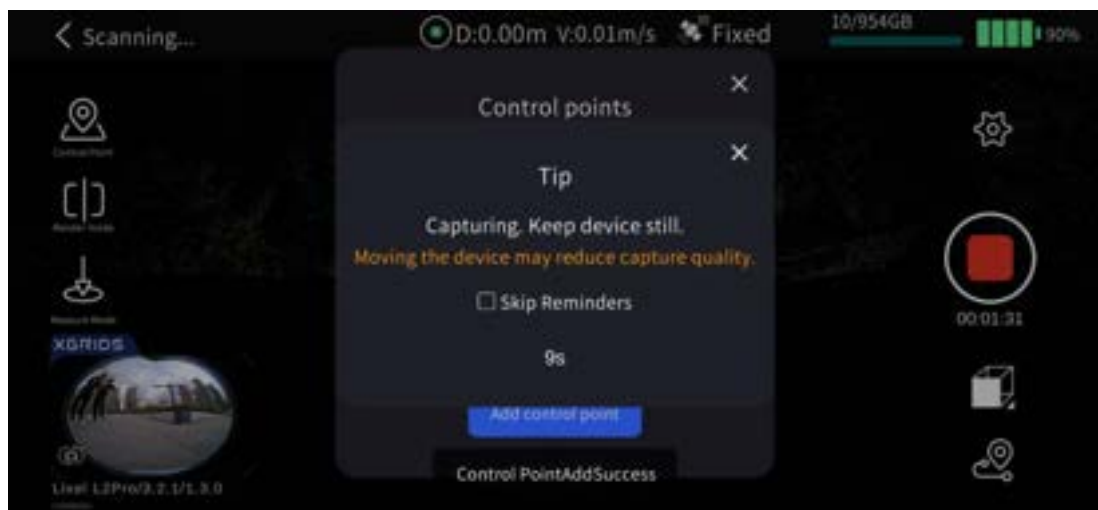

## Stop Scanning

Click the red End Recording button on the right side of the screen, then the green light of

the device will start to flash. After the light stays green, which indicates that the project was successfully saved, you can shut down the scanner or start a second scan.

### 3. Office work: Data Processing

See the LixelStudio user manual for details.

## 5.2 Through the RTK Module

With the RTK module, absolute coordinate information can be directly obtained during the scanning process, and the overall accuracy of point cloud data can be improved.

Note: In order to ensure good performance, please use this mode to scan when the outdoor RTK signal is good.

### 1. Scanner Installation

The installation components include: Lixel L2 Pro Handheld Scanner, battery, base, Survey Type RTK or Standard Type RTK.

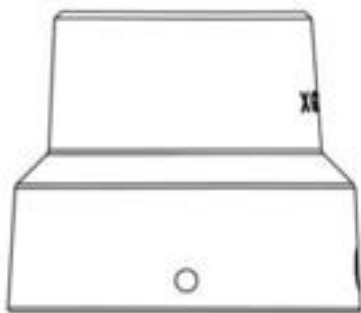

Standard Type RTK

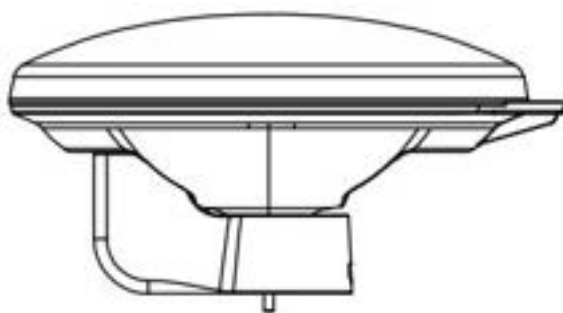

Survey Type RTK

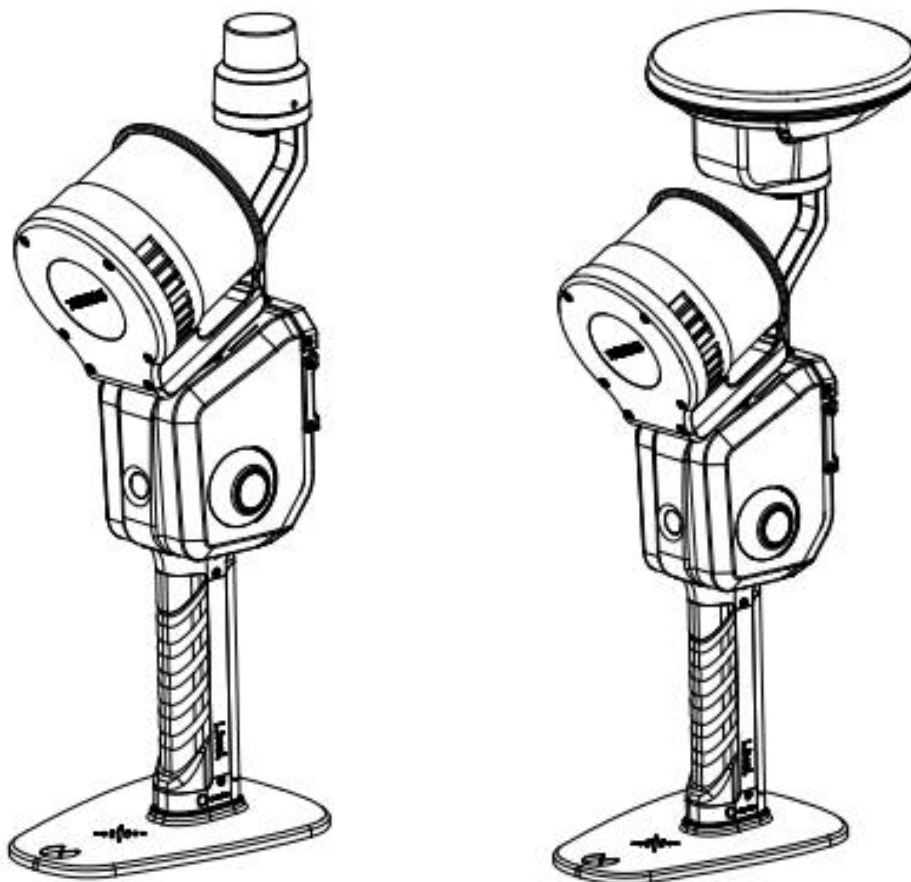

Note :

RTK module indicator lights have three statuses: red, blue and green.

Red: RTK not connected; Blue: RTK connected, not fixed; Green: RTK connected and has a fixed solution.

## 2. Field Work: Scanning

### Scan Route Planning

According to the scanning environment, plan the scanning route reasonably, and ensure that the RTK signal is good during the scanning as much as possible. If you need to ensure the accuracy of point cloud after processing in LixelStudio, please ensure that RTK with no fixed solution does not exceed 100m during the scanning.

### Connect The Device

Turn on the scanner and connect the scanner through the LixelGO App. For specific steps, please refer to the Scanning Workflow.

### RTK Account Settings

Enter the device windows, click RTK settings (satellite icon button), enter RTK settings. Currently there are 3 types of RTK configuration, custom, Qianxun, and Zhongyi. Users can configure it according to the specific situation in different areas.

Custom:

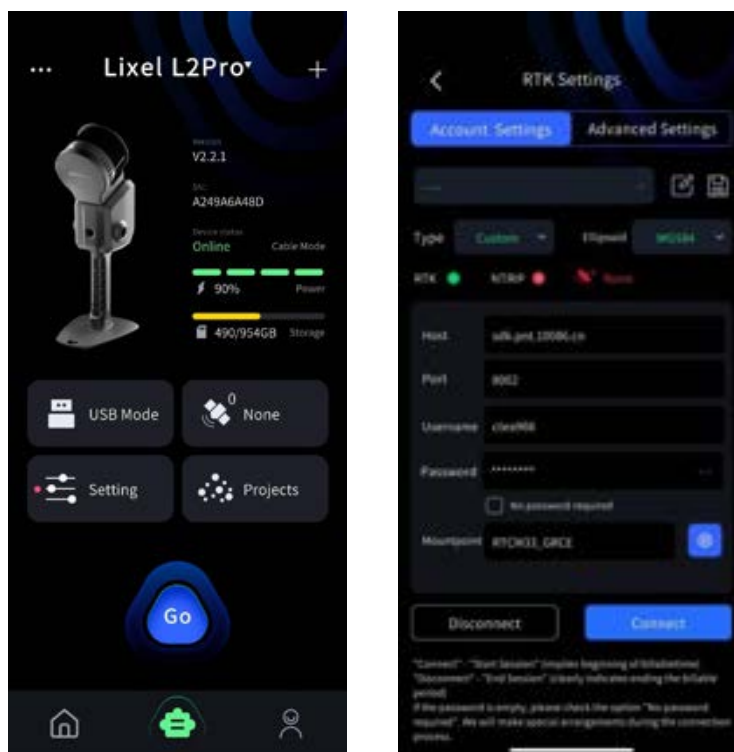

If the source ellipsoid is set to WGS84, CGCS2000, the device will generate output map .las file with absolute coordinates. Note: Currently only WGS84: UTM 3-degree zone is supported, CGCS2000: Gauss Krüger 3-degree zone is supported, where the elevation is geodetic height.

Qianxun SI and China Mobile: Users can log in by entering the corresponding account and password.

### Account Management

When there are single or multiple frequently used accounts, RTK account information can be saved to the LixelGO app cache via the "Save" button.

1. Enter RTK account information, including host, port, source node, etc.
2. Tap "Save", then select a configuration item to save in the pop-up window. The RTK account information will be saved to the LixelGO app cache.
3. Tap "Edit" to modify the configuration item name. After saving, the RTK account configuration name will be updated.
4. Saved configuration item information can be viewed in the drop-down menu.

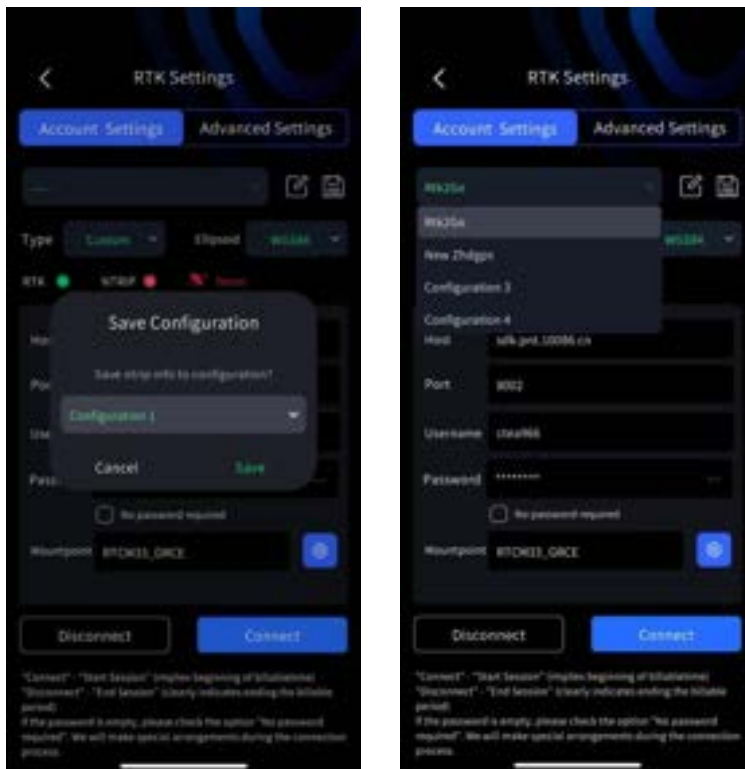

### Attention :

1. Currently, it supports Qianxun SI, China Mobile and custom RTK . To use a custom RTK, you need to ensure that the RTK data format is a common format, otherwise it cannot be used normally.

2. The first time the device and RTK account are set up, the RTK account information will be automatically recorded, and subsequent use will be automatically logged in.

3. If you want to change the RTK coordinate system, there will be a delay of about 5 minutes. It is recommended to start the operation after the change for 5 minutes

4. At present, RTK module is adaptive to WGS84, CGCS2000 and ITRF2008 reference coordinate system. And the height acquired is geodetic height.

### RTK Advanced Settings

L2 Pro has three GNSS modes.

GNSS Mode Settings	Function Definition	Description
RTK	Real-time differential correction from the RTK module recorded in the project file.	On the startup page, select the RTK mode according to the project requirements.  LixelStudio software requires an RTK module for project processing.
PPK	Post-processing correction using raw satellite data.	On the startup page, select the PPK mode according to the project requirements.  LixelStudio software requires a PPK module for project processing.
DJI	Aircraft-provided RTK.	On the startup page, select the DJI mode according to the project requirements.  LixelStudio software requires an RTK module for project processing.  For details, refer to the drone accessories section of the manual.

L2 Pro has three RTK types.

RTK Type Settings	Function Definition	Description
Standard RTK	The device will use parameters for standard RTK.	On the startup page, correctly select the RTK type mounted on the device.
Survey RTK	The device will use parameters for surveying RTK.	On the startup page, correctly select the RTK type mounted on the device.
Aerial RTK	The device will use parameters for XGRIDS drone accessories.	On the startup page, correctly select the RTK type mounted on the device.

## Satellite System Setting

In the RTK advanced settings, you can customize the selection of satellite systems. Various selection methods are supported, including single selection, multiple selection, group selection, and select all.

### Requirement

1. Firmware version 2.3.0 or above.
2. The RTK module is connected to the scanner.

### Satellite System Options

Supports various selection methods, including single selection, multiple selection, and select all.

Upon entering the RTK advanced settings, the device's satellite system settings will be automatically read and displayed.

After selecting the satellite system and clicking "Settings", a Toast notification will appear to indicate that the settings were successful.

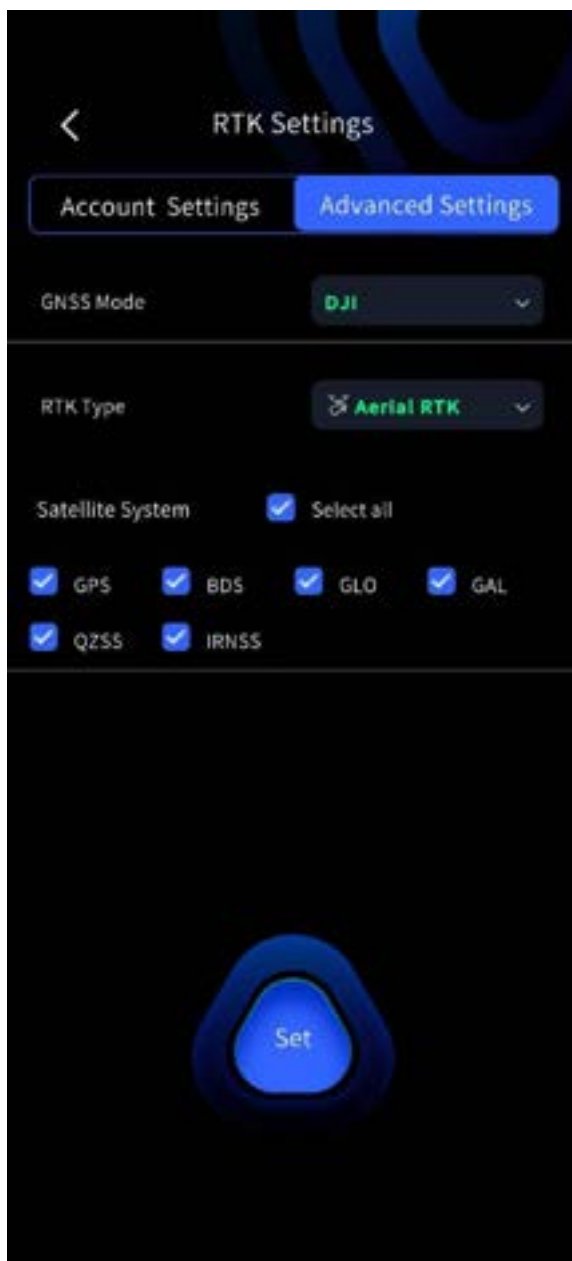

## Start Scanning

In RTK mode, you need to wait for the RTK module indicator light to turn green, and the App displays that the RTK signal becomes Fixed before picking up the scanner and starting the scanning operation.

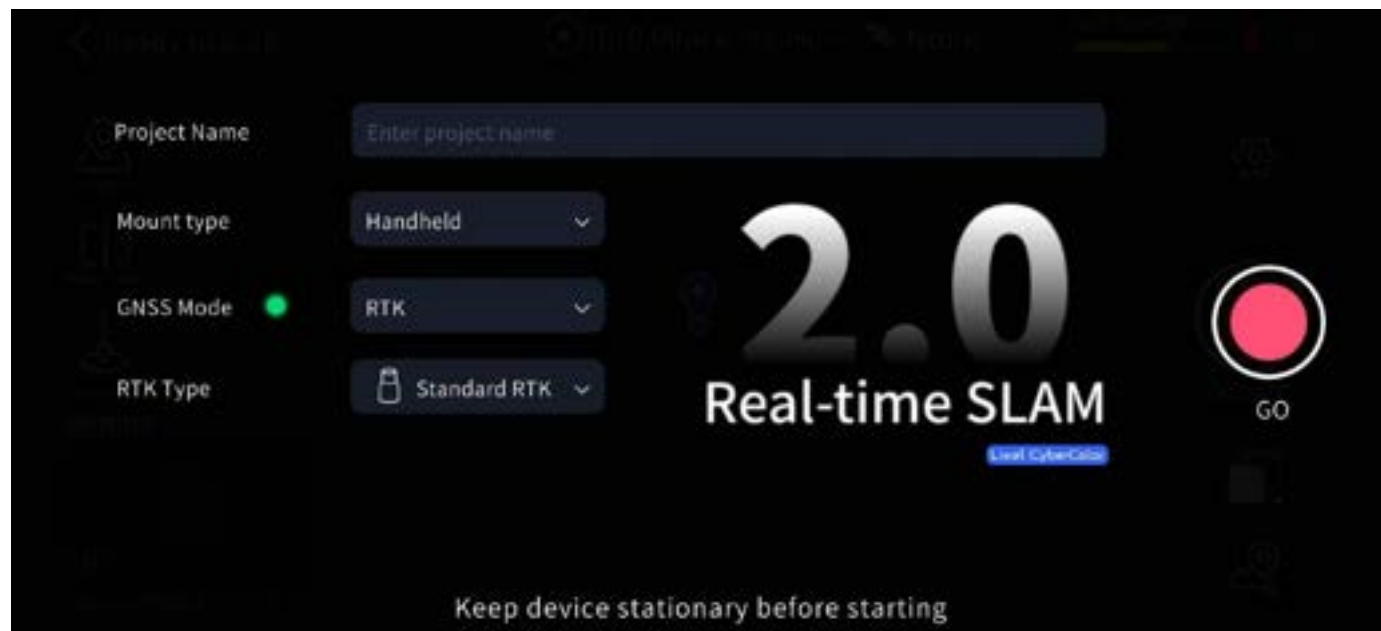

### **Attention :**

1. RTK mode only supports scenes with RTK signals outdoors. RTK will not be able to obtain a fixed solution in indoor scenes.
2. During the RTK fixed solution, the RTK module indicator light turns green. If the light turns blue, pay attention to the satellite number.
3. Only if the satellite status on the App is fixed, you can start the scan. It can not be NONE, float, or single.
4. In order to ensure accuracy, it is recommended that the device stays in a fixed solution state most of the time during the scanning process. It is necessary to ensure that the RTK valid data is  $> 100$  to achieve coordinate conversion successfully in LixelStudio.
5. When scanning, keep the L2 Pro scanner vertical and avoid tilting. When walking, the inclination angle of the scanner generally does not exceed  $20^\circ$ . In special cases, such as when scanning a small space or ground targets, the inclination angle of the device should not exceed  $30^\circ$ . Please refer to the posture indicator on the screen and adjust your device posture accordingly. You should try to avoid this warning message as much as possible.



6. Ensure that while the satellite status stays at "fixed", device movement should be larger than 10 meters during scanning. Otherwise, Lixel Studio might be unable to perform project-processing.

### Stop Scanning

Click the red End Recording button on the right side of the screen, then the green light of the device will start to flash. After the light stays green, which indicates that the project was successfully saved, you can shut down the scanner or start a second scan.

## 4. Office Work: Data Processing

See the LixelStudio instruction user manual for details.

## 6 Measure Point

In scenarios where RTK signal lock is lost (such as in tunnels, beneath overpasses, or inside buildings), the combination of SLAM mapping technology and real-time RTK fusion still provides the ability to obtain absolute coordinates within a certain walking distance.

After losing RTK connection, L2 Pro ensures that when the walking trajectory distance is smaller than 50 meters, the horizontal and vertical accuracy of absolute coordinate is maintained within 5 cm. Within a 100 meter walking trajectory distance, the horizontal and vertical accuracy of absolute coordinates is maintained within 10 cm.

## 6.1 Usage Scenario/Requirement

1. 2.3.0 or higher firmware version.
2. RTK module is connected to the scanner.
3. RTK source ellipsoid is either WGS84 or CGCS2000.
4. After the device initialization is complete, while the RTK is in a "fixed" state, you need to walk a 10-meter by 10-meter L-shaped route to ensure RTK accuracy.
5. It is necessary to scan at least three sides of the surveyed building/area with RTK status being fixed.
6. Walking distance might not be larger than 100m when the RTK signal is lost.
7. Ensure that the scanning procedure is strictly followed (with no extreme operations; use normal scanning posture).

## 6.2 Example

**Example:**

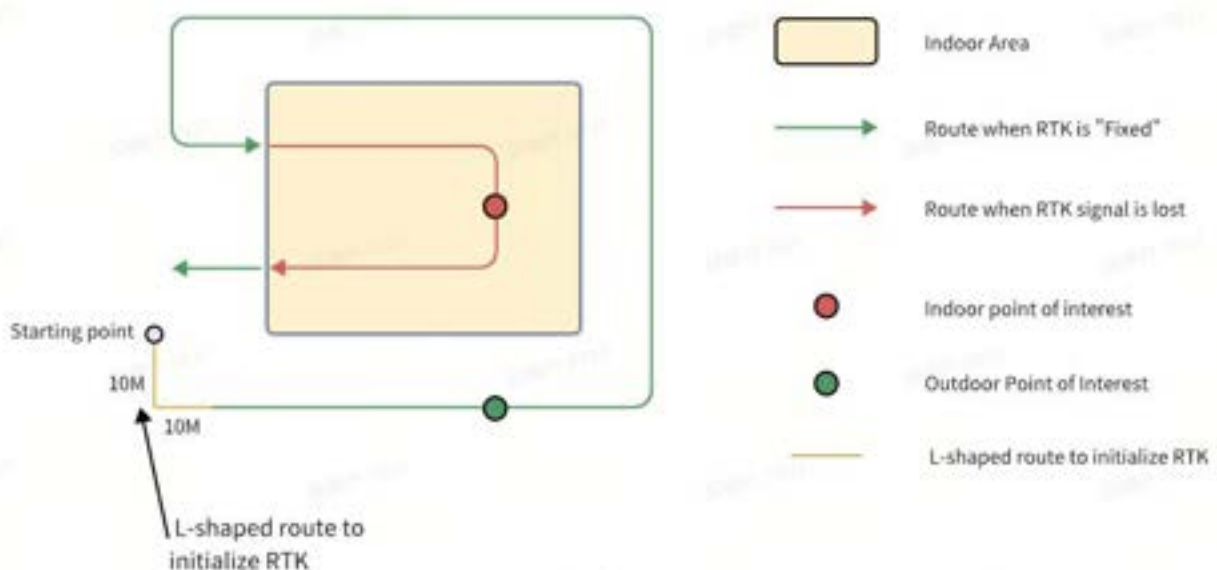

The green line represents the route with a fixed RTK solution, and the red line represents

there RTK signal is disconnected. If the walking trajectory distance between the measurement point and where RTK status is lost (the building entrance in this case) is within 50 meters, the absolute coordinate accuracy of the measurement point can be maintained within 5 cm. If the walking trajectory distance between the measurement point and the RTK conversion point at the entrance is within 100 meters, the absolute coordinate accuracy of the measurement point can be maintained within 10 cm.

### Point Measurement Result Files:

On the Projects page on the Lixel Go app, click on the "..." on the scanned project and you can choose to download the measurement point file (measure\_points\_latest.csv) to your phone.

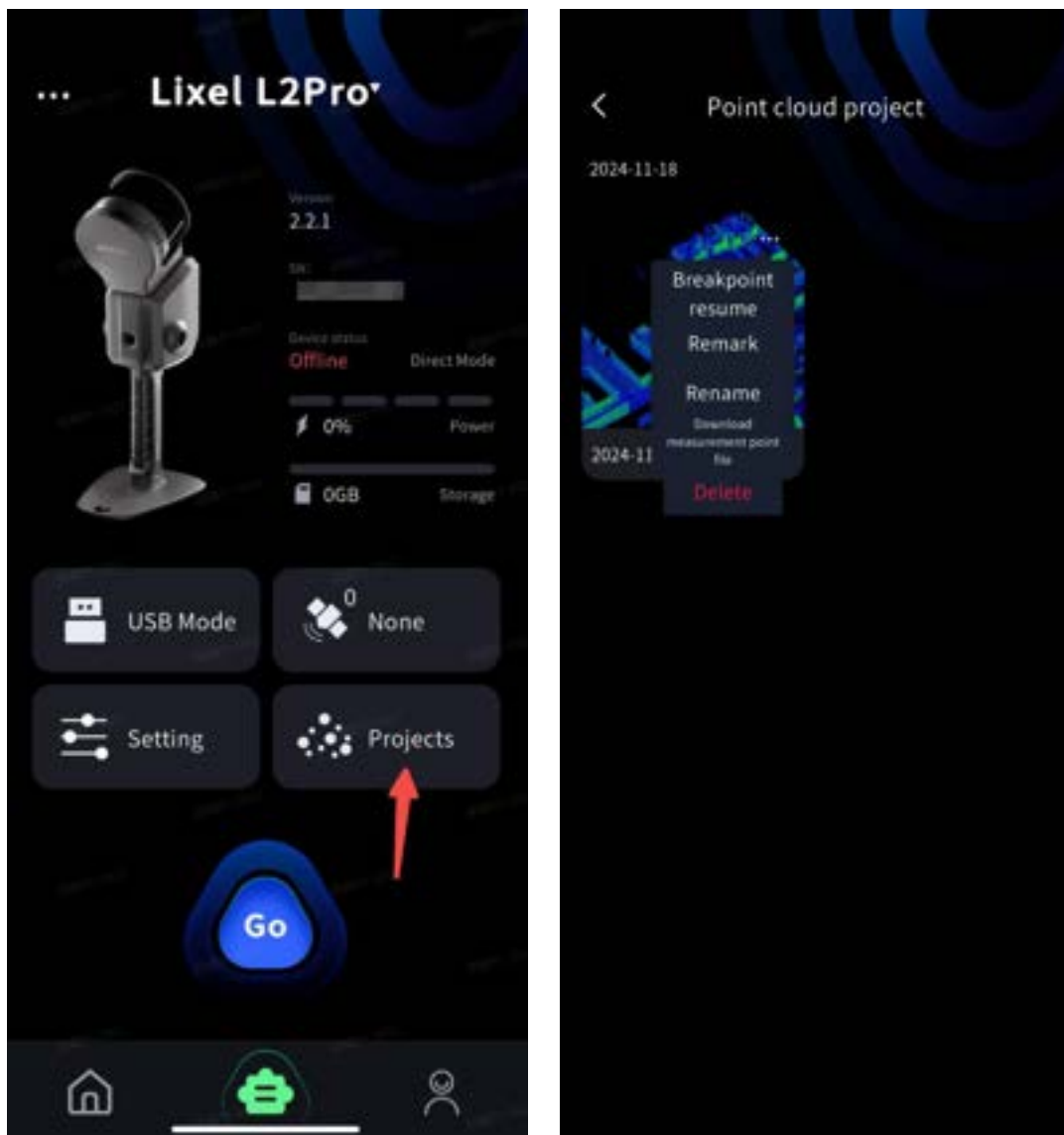

In the project\_data folder, the real-time measurement result and the SLAM-optimized real-time measurement result will be saved in measure\_points.csv and measure\_points\_latest.csv respectively.

File path:	Note:
/project_data/measure_points.csv	This file records the real-time measurement result, same as the results shown on the Lixel Go app during your scan.
/project_data/measure_points_latest.csv	This file records the optimized measurement result. It might be slightly different from the numbers shown on the App during the scan. When you download measurement point file from Lixel Go app, this file will be downloaded.

The contents of the files measure\_points.csv and measure\_points\_latest.csv are identical; the difference is that measure\_points\_latest.csv contains optimized results. It is recommended to use the results from measure\_points\_latest.csv.

Column Names:

#timestamp	timestamp
id	Id of the points measured
type	GNSS type (i.e. "2" for wgs84 or "3" for cgcs2000)
label	Point name
B	Latitude(°)
L	Longitude(°)
H	Altitude(m)
E	Easting(m)
N	Northing(m)
Z	Altitude(m)
undulation	Geoid undulation (N)
std	Standard Deviation of the measured points(m)

x	Point x
y	Point y
z	Point z

## 7 Appendix

### 7.1 Specifications

Category	Subcategory	L2 Pro	Remarks
System Parameter	Handheld Unit Weight	1.7kg(without battery)	No battery
	Dimensions	180mm×130mm×400mm	Includes battery, base, but not RTK or phone holder components.
	Outer Casing	Industrial-grade Aluminium	
	Power Consumption	<30W	
	Data Interface	USB 3.1 Gen2	
	Storage	1T SSD	
	Operating Time	1.5h	
	Wireless Module	Supports WiFi, Bluetooth: 802.11a/b/g/n/ac, 2.4GWifi 2412-2472MHz 5G2 WiFi 5180-5240MHz 5G8 WiFi 5745-5825MHz	
Working environment	Operating Temperature	-20°C~50°C	
	IP Rating	IP54	
Functions	Visual SLAM Positioning	Supported	
	Real-time	Supported	

## XGRIDS Lixel L2 Pro User Manual

	Colored Point Cloud		
	Real-time RTK fusion	Supported	
Output	Point Cloud Format	.las	
	Image Formats	.jpg	
Real-time Accuracy	Absolute Accuracy - Elevation (RMSE)	3cm	RTK disconnection < 100m
	Absolute Accuracy - Horizontal (RMSE)	3cm	RTK disconnection < 100m
	Relative Accuracy (RMSE)	2cm	The distance between two points is less than 100m.
Post-Processed Accuracy	Absolute Accuracy - Elevation (RMSE)	3cm	Control point/RTK disconnection < 100m
	Absolute Accuracy - Horizontal (RMSE)	3cm	Control point/RTK disconnection < 100m
	Relative Accuracy (RMSE)	1cm	The distance between two points is less than 100m.
	Repeatability (max)	2cm	Two scans with RTK, no disconnection
	Point Cloud Thickness	0.5cm	Planar thickness of point cloud within 10m of walking path
	Horizontal	0.015°	RTK : RTK with non-fixed

## XGRIDS Lixel L2 Pro User Manual

	Accuracy (RTK/Control point Fusion)		spacing less than 100m. Control point: Control point spacing less than 100m.
	LixelUpSample	Supported	
LiDAR	Scanning Range	0.5m~120m 0.5m~300m	
	Laser Class	Class 1 / 905nm	
	Field of View (FOV)	360°×270°	
	Scan Rate	320,000 points/s 640,000 points/s	
Camera for Panoramic Images	Camera Resolution	2×48MP	
	Panoramic Image Resolution	Max 56MP	
	Focal Length	2mm	
	Aperture	F/2.0	
	CMOS	1/2"	
	Shutter type	Rolling shutter	
	Field of View (FOV)	190°×190°	
Camera for Visual Positioning	Resolution	1×1MP	
	Shutter	Global shutter	
	FOV	190°×119°	
Battery	Voltage	14.4V	

## XGRIDS Lixel L2 Pro User Manual

	Capacity	46.8wh	
Charging	Input	100V~240V,100V~240V,50 ~ 60 HZ 1.5A 80VA 50 ~ 60 HZ 1.5A 80VA	
	Output	16.816.8V 2.0A V 2.0A	
	Power	34W	
Accessories	Backpack Scanning System	Dimensions: 60cm×60cm×15cm Weight: 2.5KG	
	Backpack	Dimensions: 55cm×35cm×25cm Weight: 2.7KG	
	Standard RTK+ bracket	Supported channels: GPS L1/L2/L5 GLONASS L1/L2 BDS B1/B2/B3 Galileo E1/E5a/E5b/E6b Accuracy: Horizontal: 0.8 cm + 1 ppm Elevation: 1.5 cm + 1 ppm Antenna: Impedance: 50 ohms Polarization mode: right-handed circular polarization Horizontal coverage angle: 360 ° Output standing wave: ≤ 2.0 Maximum Gain: 2.8dBi	Test results may be biased by atmospheric conditions, base line length, GNSS antenna type, multipath, number of visible satellites, and satellite geometry. Without considering possible antenna phase center offset errors, it is recommended to use a receiver with a 1-kilometer base line and good antenna performance for measurement.
	Surveying RTK + bracket	Supported channels: GPS L1/L2/L5 GLONASS L1/L2	

		<p>BDS B1/B2/B3 Galileo E1/E5a/E5b/E6b Accuracy: Horizontal: 0.8 cm + 1 ppm Elevation: 1.5 cm + 1 ppm Antenna: Impedance: 50 ohms Polarization mode: right-handed circular polarization Antenna axis ratio: <math>\leq 3\text{dB}</math> Horizontal coverage angle: <math>360^\circ</math> Output standing wave: <math>\leq 2.0</math> Maximum Gain: 5.5dBi</p>	
	2m Extension Pole	Supported	
	Phone Mount	Supported	
	GCP Collection Base	Supported	
	Shipping case	Dimension: 42cm×34cm×18cm Weight with System: 6.6kg	

## 7.2 Protective Case Slots

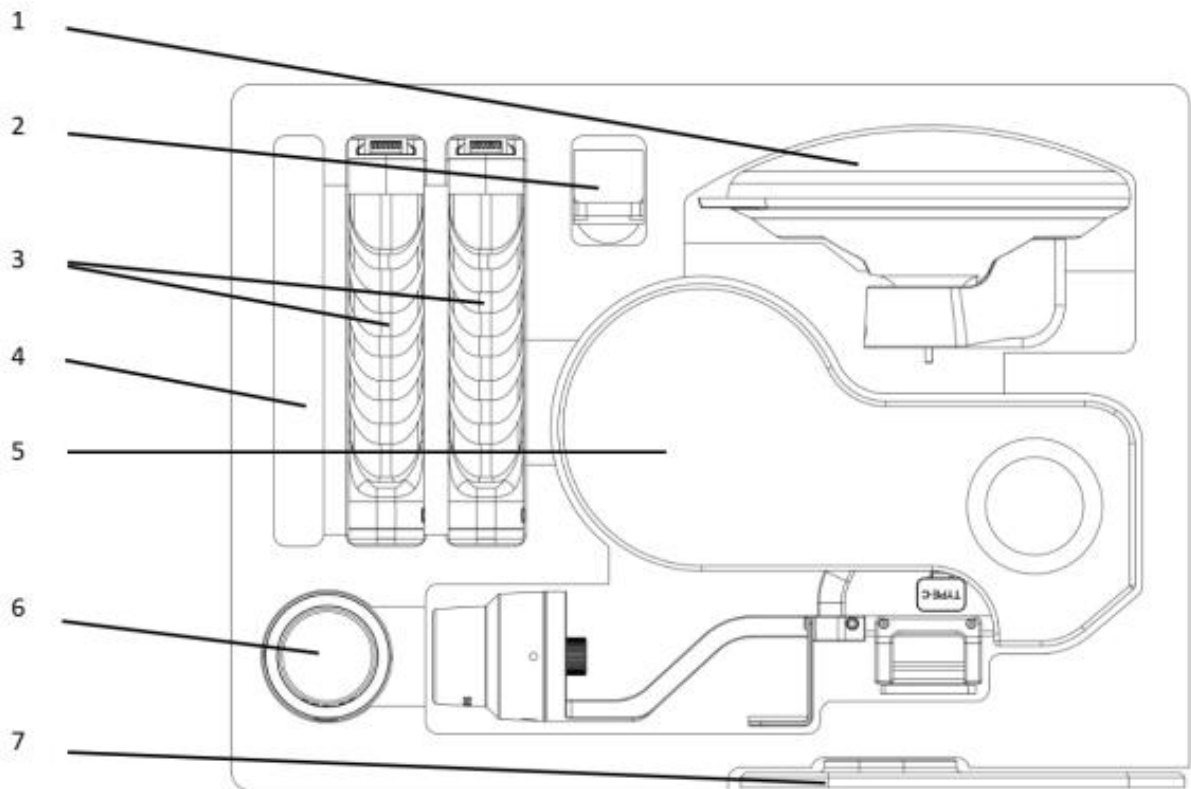

1 Survey Grade RTK Module . 2 Mobile Phone Mount. 3 Battery. 4 User Manual and USB Data Cable. 5 Device Body. 6 Standard RTK Module. 7 GCP Collection Base.

## 7.3 Accessories

### L2 Pro Drone Mounting Bracket User Manual

L2 Pro Drone Mounting Kit contains the following:

Mounting Bracket	Gimbal Adapter Ring
------------------	---------------------



Custom Type-C Cable

Installation Toolkit: The installation toolkit includes screws: M2.5×5, M2.5×10, M3×8.



## Required equipment

L2 Pro

DJI M300/M350 with gimbal



## Instructions

### Installation

1. **Attach bracket backplate** to L2 Pro (M2.5×5 screws)
2. **Connect Type-C cable** to gimbal adapter (M2.5×8 screws)



3. **Mount bracket** to drone using existing gimbal holes (M3×8 screws)

**Note:** Ensure that the arrow indicated by the red box is pointing toward the gimbal adapter ring.



4. Install the gimbal adapter ring on the M300/M350.



**5. Secure L2 Pro** in bracket and engage green safety lock. This will lock the red-boxed tension button to ensure the device remains securely attached during flight.

**Critical:** The **green-boxed button** is a **safety lock** and must remain **engaged** to prevent the L2 Pro from falling during flight.



**6. Connect power and Type-C cables** and secure Type-C cable with the M2.5×8 screws.

**Critical:** Secure Type-C cable to prevent RTK disconnection during flight.



## 7.Illustration of the completed installation

Top view	Front view	Left view
		

### Data Collection:

1.Update LixelGO to version 1.2.0 or above.

**2.Power sequence:** Drone first, then L2 Pro. L2 Pro will use the drone as its power source.



3.Use LixelGO to start scanning.

- (1) Set the mount type to: Drone
- (2) RTK type: Aerial
- (3) Drone source ellipsoid: match the coordinate system used on the DJI remote controller (WGS84/CGCS200)

**Important:** LixelGO must be used to start the scan for the project file to register the correct mounting mode, RTK type, and coordinate system information.

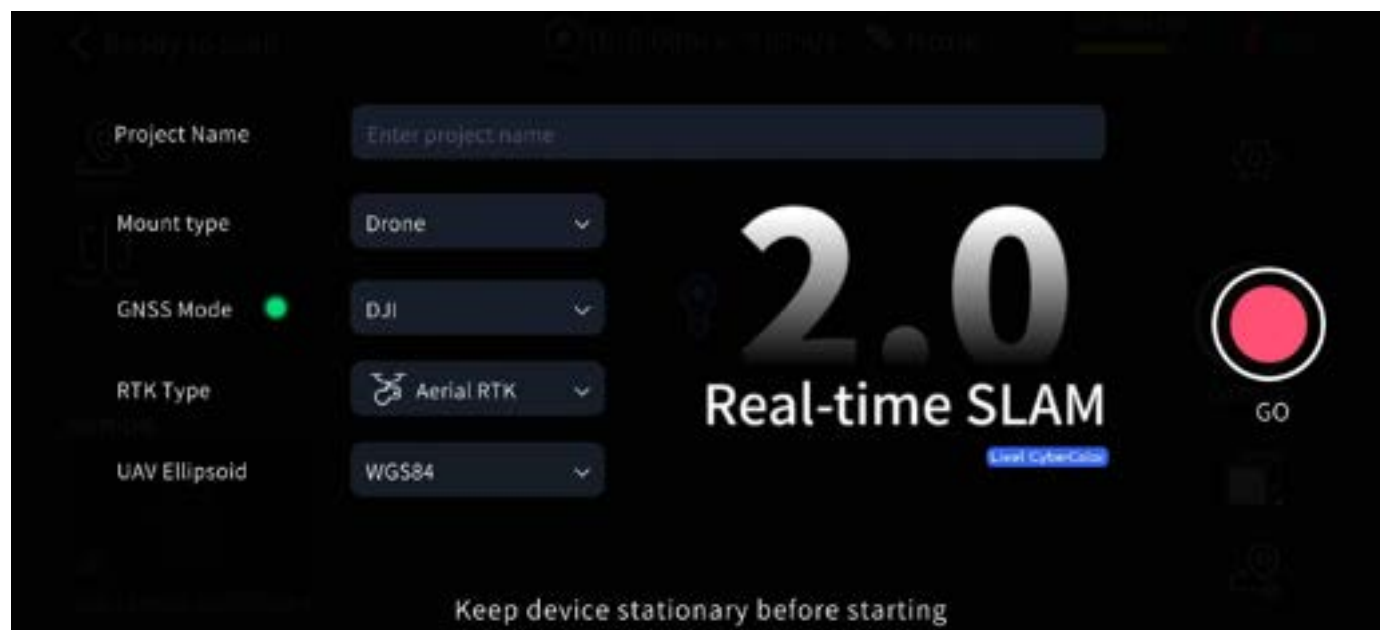

4. **DJI Remote Controller:** Set the flight route and begin the mission at a constant speed. After the drone returns, stop the scan and power off normally.

#### 5. **Flight Route Information:**

- (1) **Recommended:** 3 m/s at 30 m altitude.
- (2) **Maximum:** 5 m/s at 50 m altitude.
- (3) **Flight Distance:** Unlimited.

#### **Project Processing:**

1. Software: Update LixelStudio to version 3.3 or higher.
2. Process: Click Project Processing, then Select Project File. LixelStudio will automatically detect the recorded mount type and ellipsoid information.

# XGRIDS Lixel L2 Pro User Manual

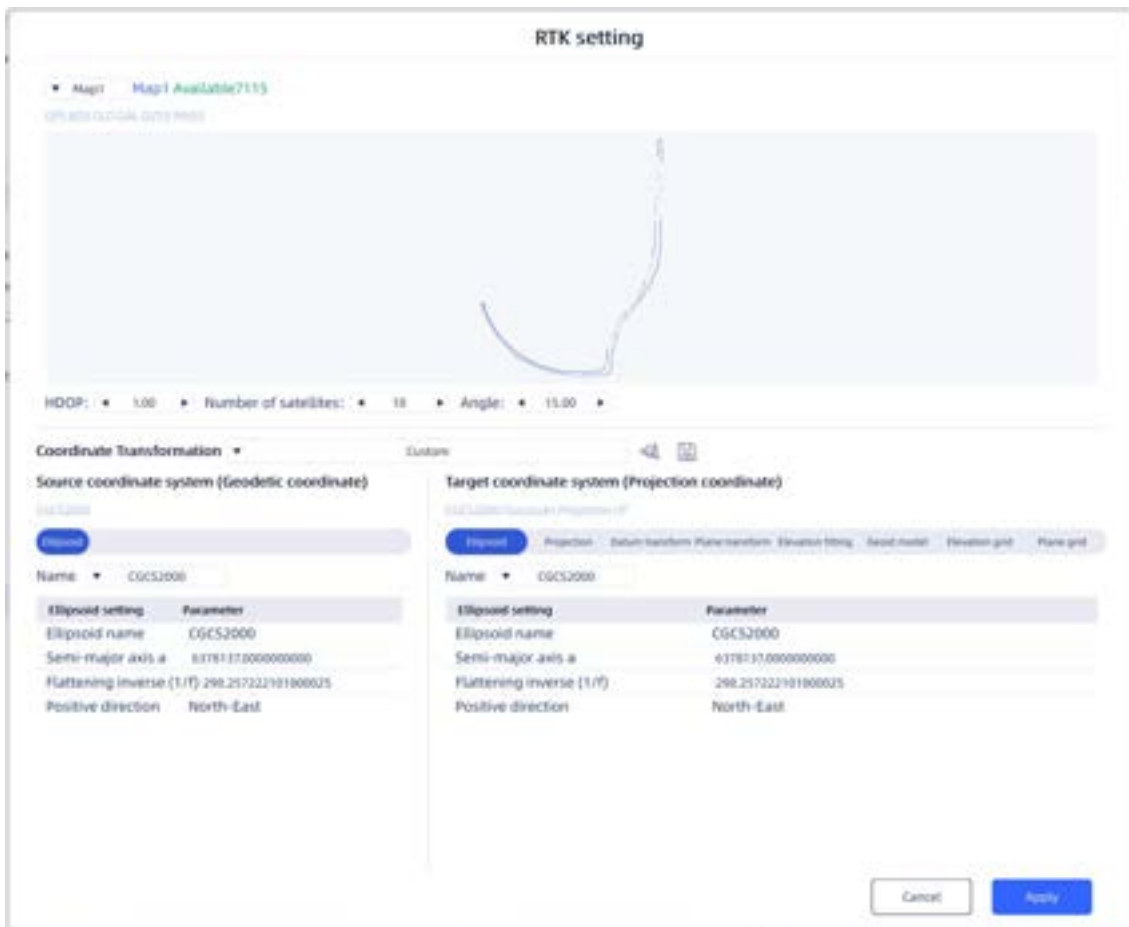
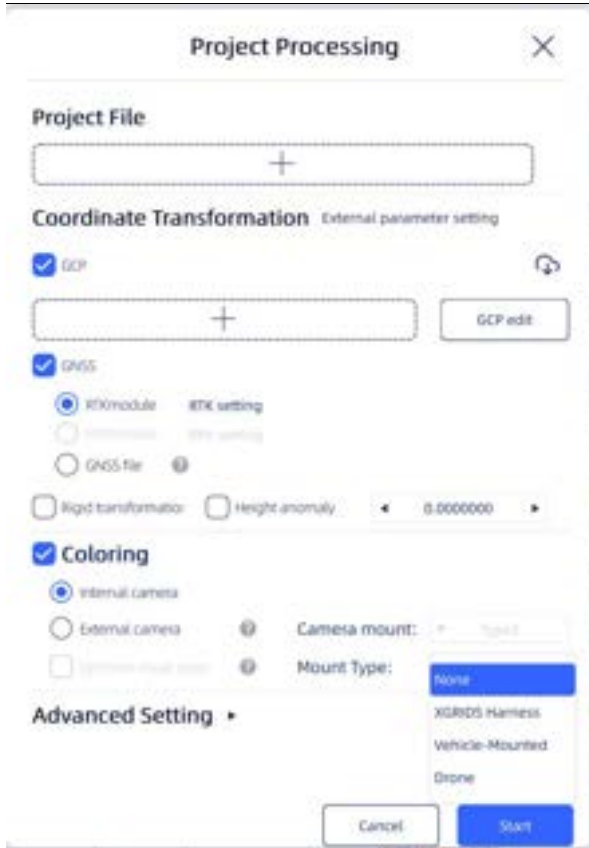

**Important Note:**

**Incorrect Parameters:** If data collection parameters were set incorrectly, adjust the options in LixelStudio's Project Processing as shown in the image, and change the **tilt angle to 180°**.

**Coordinate System:** The coordinate system defaults to **CGCS2000**. Before processing, confirm the coordinate system settings to prevent a drop in absolute accuracy.

Once settings are complete, click **Start** to begin project processing automatically.