

Leica BLK360



User Manual
Version 4.0
English

- when it has to be **right**

Leica
Geosystems

PART OF
HEXAGON

Introduction

Purchase

Congratulations on the purchase of a Leica BLK360 series instrument.



This manual contains important safety directions as well as instructions for setting up the product and operating it. Refer to **1 Safety Directions** for further information.

Read carefully through the User Manual before you switch on the product.

To ensure safety when using accompanying battery charger, also observe the directions and instructions contained in the User Manual of the battery charger.

Product identification

The model and serial number of your product are indicated on the type plate.

Always refer to this information when you need to contact your agency or Leica Geosystems authorised service centre.

Leica Geosystems address book

On the last page of this manual, you can find the address of Leica Geosystems headquarters. For a list of regional contacts, please visit http://leica-geosystems.com/contact-us/sales_support.

Table of Contents

1	Safety Directions	5
1.1	General Introduction	5
1.2	Definition of Use	6
1.3	Limits of Use	6
1.4	Responsibilities	6
1.5	Hazards of Use	7
1.6	Laser Classification	10
	1.6.1 General	10
	1.6.2 Scanning Laser	10
1.7	Electromagnetic Compatibility (EMC)	11
1.8	FCC Statement, Applicable in U.S.	13
1.9	IC Statement, Applicable in Canada	14
2	Description of the System	15
2.1	System Components	15
2.2	Container Contents	15
2.3	Instrument Components	16
3	User Interface	17
3.1	Power Button	17
3.2	Instrument Status	17
4	Operation	20
4.1	Instrument Setup	20
	4.1.1 General Information	20
	4.1.2 Tripod Setup	20
	4.1.3 Floor Stand Setup	21
4.2	Operation - Getting Started	21
4.3	Imaging	25
4.4	Scanning	25
	4.4.1 Ambient Conditions	25
	4.4.2 Troubleshooting	26
	4.4.3 Field of View (FoV)	27
4.5	Data Transfer	27
4.6	Power Supply	28
	4.6.1 Battery and Charger Safety	28
	4.6.2 Charging Station	29
	4.6.3 Internal Battery	32
5	Care and Transport	33
5.1	Maintenance	33
5.2	Transport	33
5.3	Storage	33
5.4	Cleaning and Drying	33
5.5	Glass Cleaning Procedure	34
6	Technical Data	35
6.1	General Technical Data of the Product	35
6.2	System Performance	35
6.3	Laser System Performance	35
6.4	Electrical Data	37
6.5	Environmental Specifications	37
	6.5.1 BLK360	37
	6.5.2 Charger and Batteries	38
6.6	Dimensions	38
6.7	Weight	40

6.8	Accessories	40
6.9	Conformity to National Regulations	40
6.9.1	BLK360	40
6.9.2	Dangerous Goods Regulations	41
7	Software Licence Agreement/Warranty	42

1 Safety Directions

1.1 General Introduction

Description

The following directions enable the person responsible for the product, and the person who actually uses the equipment, to anticipate and avoid operational hazards.

The person responsible for the product must ensure that all users understand these directions and adhere to them.

About warning messages





Warning messages are an essential part of the safety concept of the instrument. They appear wherever hazards or hazardous situations can occur.

Warning messages...

- make the user alert about direct and indirect hazards concerning the use of the product.
- contain general rules of behaviour.

For the users' safety, all safety instructions and safety messages shall be strictly observed and followed! Therefore, the manual must always be available to all persons performing any tasks described here.

DANGER, WARNING, CAUTION and **NOTICE** are standardised signal words for identifying levels of hazards and risks related to personal injury and property damage. For your safety, it is important to read and fully understand the following table with the different signal words and their definitions! Supplementary safety information symbols may be placed within a warning message as well as supplementary text.

Type	Description
 DANGER	Indicates an imminently hazardous situation which, if not avoided, will result in death or serious injury.
 WARNING	Indicates a potentially hazardous situation or an unintended use which, if not avoided, could result in death or serious injury.
 CAUTION	Indicates a potentially hazardous situation or an unintended use which, if not avoided, may result in minor or moderate injury.
NOTICE	Indicates a potentially hazardous situation or an unintended use which, if not avoided, may result in appreciable material, financial and environmental damage.
	Important paragraphs which must be adhered to in practice as they enable the product to be used in a technically correct and efficient manner.

1.2

Definition of Use

Intended use

- Measuring horizontal and vertical angles
 - Measuring distances
 - Capturing and recording images
 - Recording measurements
 - Remote control of product
 - Data communication with external appliances
-

Reasonably foreseeable misuse

- Use of the product without instruction
 - Use outside of the intended use and limits
 - Disabling safety systems
 - Removal of hazard notices
 - Opening the product using tools, for example screwdriver, unless this is permitted for certain functions
 - Modification or conversion of the product
 - Use after misappropriation
 - Use of products with recognisable damage or defects
 - Use with accessories from other manufacturers without the prior explicit approval of Leica Geosystems
 - Inadequate safeguards at the working site
 - Deliberate dazzling of third parties
-

1.3

Limits of Use

Environment

Suitable for use in an atmosphere appropriate for permanent human habitation. Not suitable for use in aggressive or explosive environments.

WARNING

Working in hazardous areas, or close to electrical installations or similar situations

Life Risk.

Precautions:

- ▶ Local safety authorities and safety experts must be contacted by the person responsible for the product before working in such conditions.
-

1.4

Responsibilities

Manufacturer of the product

Leica Geosystems AG, CH-9435 Heerbrugg, hereinafter referred to as Leica Geosystems, is responsible for supplying the product, including the User Manual and original accessories, in a safe condition.

Person responsible for the product

The person responsible for the product has the following duties:

- To understand the safety instructions on the product and the instructions in the User Manual
 - To ensure that it is used in accordance with the instructions
 - To be familiar with local regulations relating to safety and accident prevention
 - To inform Leica Geosystems immediately if the product and the application become unsafe
 - To ensure that the national laws, regulations and conditions for the operation of the product are respected
-

⚠ WARNING**Distraction or loss of attention**

During dynamic applications there is a danger of accidents occurring if the user does not pay attention to the environmental conditions around, for example obstacles, excavations or traffic.

Precautions:

- ▶ The person responsible for the product must make all users fully aware of the existing dangers.
-

⚠ WARNING**Inadequate securing of the working site**

This can lead to dangerous situations, for example in traffic, on building sites and at industrial installations.

Precautions:

- ▶ Always ensure that the working site is adequately secured.
 - ▶ Adhere to the regulations governing safety, accident prevention and road traffic.
-

NOTICE**Dropping, misusing, modifying, storing the product for long periods or transporting the product**

Watch out for erroneous measurement results.

Precautions:

- ▶ Periodically carry out test measurements, particularly after the product has been subjected to abnormal use and before and after important measurements.
-

⚠ CAUTION**Moving parts at the product during operation**

Risk of squeezing extremities or entanglement of hair and/or clothes.

Precautions:

- ▶ Keep a safe distance to the moving parts.
-



If the instrument moves unexpectedly during operation, stop the instrument via user interface (display, key) or alternatively remove the battery or main power source to prevent further movements.

CAUTION

Not properly secured accessories

If the accessories used with the product are not properly secured and the product is subjected to mechanical shock, for example blows or falling, the product may be damaged or people can sustain injury.

Precautions:

- ▶ When setting up the product, make sure that the accessories are correctly adapted, fitted, secured, and locked in position.
- ▶ Avoid subjecting the product to mechanical stress.

WARNING

Exposure of batteries to high mechanical stress, high ambient temperatures or immersion into fluids

This can cause leakage, fire or explosion of the batteries.

Precautions:

- ▶ Protect the batteries from mechanical influences and high ambient temperatures. Do not drop or immerse batteries into fluids.

WARNING

Short circuit of battery terminals

If battery terminals are short circuited e.g. by coming in contact with jewellery, keys, metallised paper or other metals, the battery can overheat and cause injury or fire, for example by storing or transporting in pockets.

Precautions:

- ▶ Make sure that the battery terminals do not come into contact with metallic objects.

WARNING

Inappropriate mechanical influences to batteries

During the transport, shipping or disposal of batteries it is possible for inappropriate mechanical influences to constitute a fire hazard.

Precautions:

- ▶ Before shipping the product or disposing it, discharge the batteries by the product until they are flat.
- ▶ When transporting or shipping batteries, the person in charge of the product must ensure that the applicable national and international rules and regulations are observed.
- ▶ Before transportation or shipping, contact your local passenger or freight transport company.

WARNING

Improper disposal

If the product is improperly disposed of, the following can happen:

- If polymer parts are burnt, poisonous gases are produced which may impair health.
- If batteries are damaged or are heated strongly, they can explode and cause poisoning, burning, corrosion or environmental contamination.
- By disposing of the product irresponsibly you may enable unauthorised persons to use it in contravention of the regulations, exposing themselves and third parties to the risk of severe injury and rendering the environment liable to contamination.

Precautions:

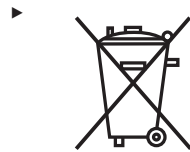

The product must not be disposed with household waste. Dispose of the product appropriately in accordance with the national regulations in force in your country. Always prevent access to the product by unauthorised personnel.

Product-specific treatment and waste management information can be received from your Leica Geosystems distributor.

WARNING

Lightning strike

If the product is used with accessories, for example masts, staffs, poles, you may increase the risk of being struck by lightning.

Precautions:

- ▶ Do not use the product in a thunderstorm.



Applies only for California. The product contains CR Lithium Cell(s) with perchlorate material inside – special handling may apply. See <http://www.dtsc.ca.gov/hazardouswaste/perchlorate/>

WARNING

Improperly repaired equipment

Risk of injuries to users and equipment destruction due to lack of repair knowledge.

Precautions:

- ▶ Only authorised Leica Geosystems Service Centres are entitled to repair these products.

For the AC/DC power supply and the battery charger:

WARNING

Unauthorised opening of the product

Either of the following actions may cause you to receive an electric shock:

- Touching live components
- Using the product after incorrect attempts were made to carry out repairs.

Precautions:

- ▶ Do not open the product!
- ▶ Only Leica Geosystems authorised service centres are entitled to repair these products.

For the AC/DC power supply and the battery charger:

WARNING

Electric shock due to use under wet and severe conditions

If unit becomes wet it may cause you to receive an electric shock.

Precautions:

- ▶ If the product becomes humid, it must not be used!
- ▶ Use the product only in dry environments, for example in buildings or vehicles.



- ▶ Protect the product against humidity.

1.6

Laser Classification

1.6.1

General

General

The following chapters provide instructions and training information about laser safety according to international standard IEC 60825-1 (2014-05) and technical report IEC TR 60825-14 (2004-02). The information enables the person responsible for the product and the person who actually uses the equipment, to anticipate and avoid operational hazards.

- ☞ According to IEC TR 60825-14 (2004-02), products classified as laser class 1, class 2 and class 3R do not require:
 - laser safety officer involvement,
 - protective clothes and eyewear,
 - special warning signs in the laser working areaif used and operated as defined in this User Manual due to the low eye hazard level.
- ☞ National laws and local regulations could impose more stringent instructions for the safe use of lasers than IEC 60825-1 (2014-05) and IEC TR 60825-14 (2004-02).

1.6.2

Scanning Laser

General

The laser incorporated in the product produces an invisible beam which emerges from the rotating mirror.

The laser product described in this section is classified as laser class 1 in accordance with:

- IEC 60825-1 (2014-05): "Safety of laser products"

These products are safe under reasonably foreseeable conditions of operation and are not harmful to the eyes provided that the products are used and maintained in accordance with this User Manual.

Description	Value
Wavelength	830 nm
Maximum pulse energy	8 nJ
Pulse duration	4 ns
Pulse repetition frequency (PRF)	1.44 MHz
Beam divergence (FWHM, full angle)	0.4 mrad
Mirror rotation	30 Hz
Base rotation	2.5 mHz

Labelling

Class 1 Laser Product according to IEC 60825-1 (2014-05)

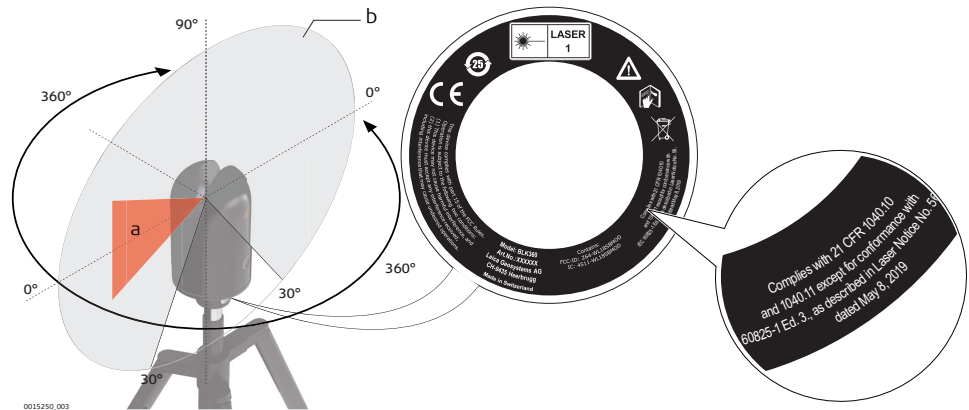

- a Laser beam
- b Scanning laser beam

1.7

Electromagnetic Compatibility (EMC)

Description

The term Electromagnetic Compatibility is taken to mean the capability of the product to function smoothly in an environment where electromagnetic radiation and electrostatic discharges are present, and without causing electromagnetic disturbances to other equipment.

 **WARNING**

Electromagnetic radiation

Electromagnetic radiation can cause disturbances in other equipment.

Precautions:

- ▶ Although the product meets the strict regulations and standards which are in force in this respect, Leica Geosystems cannot completely exclude the possibility that other equipment may be disturbed.

 **CAUTION**

Use of the product with accessories from other manufacturers. For example field computers, personal computers or other electronic equipment, non-standard cables or external batteries

This may cause disturbances in other equipment.

Precautions:

- ▶ Use only the equipment and accessories recommended by Leica Geosystems.
- ▶ When combined with the product, they meet the strict requirements stipulated by the guidelines and standards.
- ▶ When using computers, two-way radios or other electronic equipment, pay attention to the information about electromagnetic compatibility provided by the manufacturer.

 **CAUTION**

Intense electromagnetic radiation. For example, near radio transmitters, transponders, two-way radios or diesel generators

Although the product meets the strict regulations and standards which are in force in this respect, Leica Geosystems cannot completely exclude the possibility that function of the product may be disturbed in such an electromagnetic environment.

Precautions:

- ▶ Check the plausibility of results obtained under these conditions.

 **WARNING**

Use of product with radio or digital cellular phone devices

Electromagnetic fields can cause disturbances in other equipment, in installations, in medical devices, for example pacemakers or hearing aids and in aircrafts. Electromagnetic fields can also affect humans and animals.

Precautions:

- ▶ Although the product meets the strict regulations and standards which are in force in this respect, Leica Geosystems cannot completely exclude the possibility that other equipment can be disturbed or that humans or animals can be affected.
- ▶ Do not operate the product with radio or digital cellular phone devices in the vicinity of filling stations or chemical installations, or in other areas where an explosion hazard exists.
- ▶ Do not operate the product with radio or digital cellular phone devices near to medical equipment.
- ▶ Do not operate the product with radio or digital cellular phone devices in aircrafts.
- ▶ Do not operate the product with radio or digital cellular phone devices for long periods with the product immediately next to your body.

1.8

FCC Statement, Applicable in U.S.

 **WARNING**

This equipment has been tested and found to comply with the limits for a Class B digital device, pursuant to part 15 of the FCC rules.

These limits are designed to provide reasonable protection against harmful interference in a residential installation.

This equipment generates, uses and can radiate radio frequency energy and, if not installed and used in accordance with the instructions, may cause harmful interference to radio communications. However, there is no guarantee that interference will not occur in a particular installation.

If this equipment does cause harmful interference to radio or television reception, which can be determined by turning the equipment off and on, the user is encouraged to try to correct the interference by one or more of the following measures:

- Reorient or relocate the receiving antenna.
- Increase the separation between the equipment and the receiver.
- Connect the equipment into an outlet on a circuit different from that to which the receiver is connected.
- Consult the dealer or an experienced radio/TV technician for help.

 **CAUTION**

Changes or modifications not expressly approved by Leica Geosystems for compliance could void the user's authority to operate the equipment.

Labelling

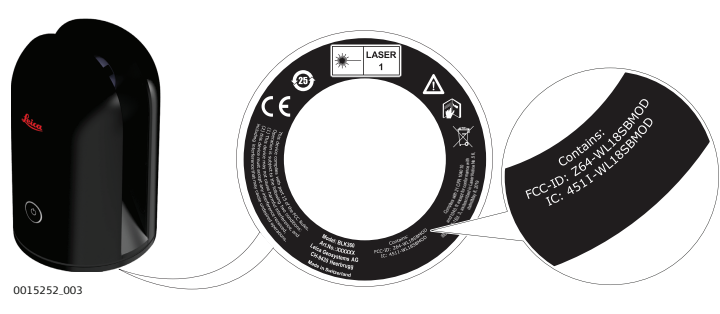

Labelling GEB212

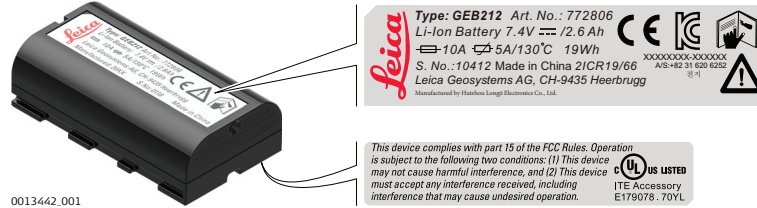

Type Plate Labelling GKL312

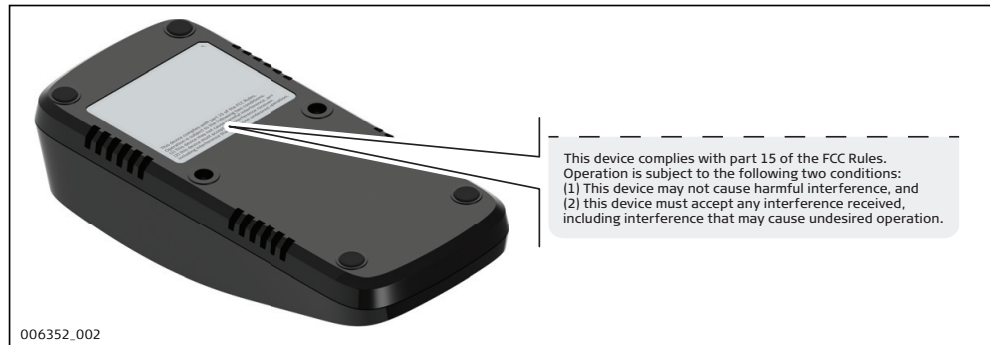

1.9

IC Statement, Applicable in Canada

⚠ WARNING

This Class (B) digital apparatus complies with Canadian ICES-003.
Cet appareil numérique de la classe (B) est conforme à la norme NMB-003 du Canada.

Canada Compliance Statement

This device contains licence-exempt transmitter(s)/receiver(s) that comply with Innovation, Science and Economic Development Canada's licence-exempt RSS(s). Operation is subject to the following two conditions:

1. This device may not cause interference.
2. This device must accept any interference, including interference that may cause undesired operation of the device.

Canada Déclaration de Conformité

L'émetteur/récepteur exempt de licence contenu dans le présent appareil est conforme aux CNR d'Innovation, Sciences et Développement économique Canada applicables aux appareils radio exempts de licence. L'exploitation est autorisée aux deux conditions suivantes:

1. L'appareil ne doit pas produire de brouillage;
2. L'appareil doit accepter tout brouillage radioélectrique subi, même si le brouillage est susceptible d'en compromettre le fonctionnement.

2

Description of the System

2.1

System Components

System components BLK360



- a BLK360 instrument and hood with floor stand
- b GEB212 batteries
- c GKL312 charging station
- d GEV192-9 AC/DC power supply for GKL312
- e BLK360 mission bag
- f BLK360 tripod adapter
- g Tripod

2.2

Container Contents

Container contents

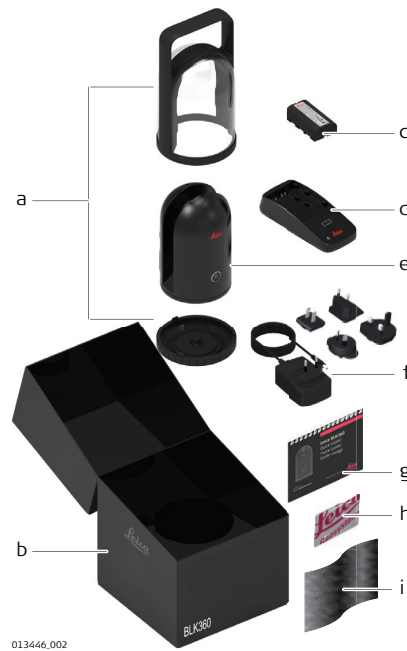

- a BLK360 hood with floor stand
- b BLK360 box
- c GEB212 internal battery
- d GKL312 charging station
- e BLK360
- f GEV192-9 AC/DC power supply for GKL312
- g BLK360 Quick Guide
- h BLK360 System USB swing card
- i Cleaning cloth

2.3

Instrument Components

Instrument components

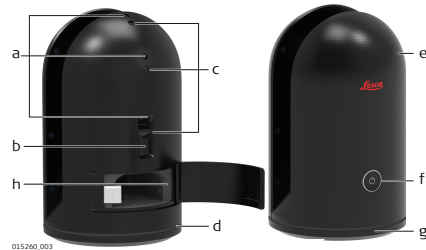

- a Flash light for HDR camera
- b Thermal camera (available in special product variant)
- c HDR camera
- d Ring-shaped LED
- e Scanner 360 °
- f Power button
- g 360 ° WLAN antenna
- h USB-C Gigabit-Ethernet port

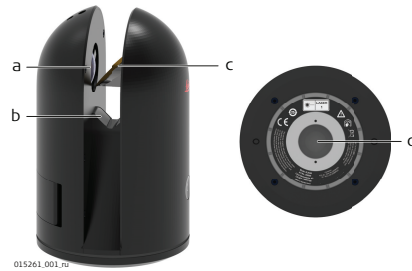

- a Laser aperture
- b Nadir reference plate
- c Rotating prism
- d Quick release mount

3

User Interface

3.1

Power Button

Power button



a Power button

Power button	when the BLK360 is	THEN
Press and hold the button <0.5 sec.	off.	The BLK360 switches on and the LED starts blinking yellow.
Press and hold the button <0.5 sec.	on and ready. The LED is continuous green.	After counting down for 10 seconds the BLK360 starts recording and the LED starts blinking yellow.
Press and hold the button >2 sec.	on and ready. The LED is continuous green.	The LED starts blinking yellow and the BLK360 switches off.
Press and hold the button > 5 sec.	on.	The BLK360 switches off immediately. Hard shut-down.

NOTICE

It is mandatory to follow always this procedure to shut down the instrument. Do not remove the battery from a running instrument!

3.2

Instrument Status





Device status

The ring-shaped LED lights up green, yellow or red in different intervals to show the operation states of the BLK360.





- a Ring-shaped LED continuous
- b Ring-shaped LED blinking
- c Ring-shaped LED alternating

Operation mode

LED status	Instrument status
	The BLK360 is off.
	The BLK360 is starting, recording or switching off.
	The BLK360 is ready. Bright green: Battery capacity > 20%. Dark green: Battery capacity < 20%. In case of low battery, refer to Insert and remove the internal battery .
	The BLK360 is counting down before recording. The countdown time is 10 seconds.

Firmware update mode

LED status	Instrument status
	The BLK360 is running a firmware update.
	The firmware update was successful.

LED status**Instrument status**

The firmware update failed.



Refer to the help menu in the Leica BLK360 app for details about firmware update process.



4 Operation

4.1 Instrument Setup

4.1.1 General Information

Use the tripod

The instrument should always be set up on its floor stand or tripod. Using the tripod specified for the scanning system guarantees maximum stability during scanning operations.

-  Do not set up the instrument directly on the ground without the floor stand or tripod connected.
-  It is always recommended to shield the instrument from direct sunlight and avoid uneven temperatures around the instrument.

4.1.2 Tripod Setup

BLK360 setup step-by-step

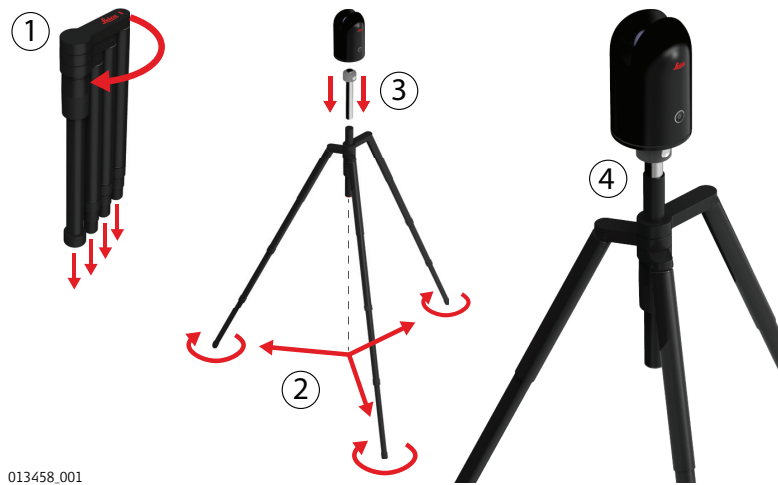

013458_001

1. Unfold the tripod and extend the tripod legs to allow for a comfortable working posture.
2. Tighten the screws of the legs and expand the legs for a stable tripod position.
3. Place the tripod adapter on the tripod and secure it.
4. Place the instrument on the tripod adapter and secure it.

4.1.3

Floor Stand Setup

BLK360 setup step-by-step



1. Open the BLK360 hood.
2. Turn around the bottom plate by 180 degrees.
3. Place the BLK360 on the bottom plate.

4.2

Operation - Getting Started

Stand-alone operation step-by-step

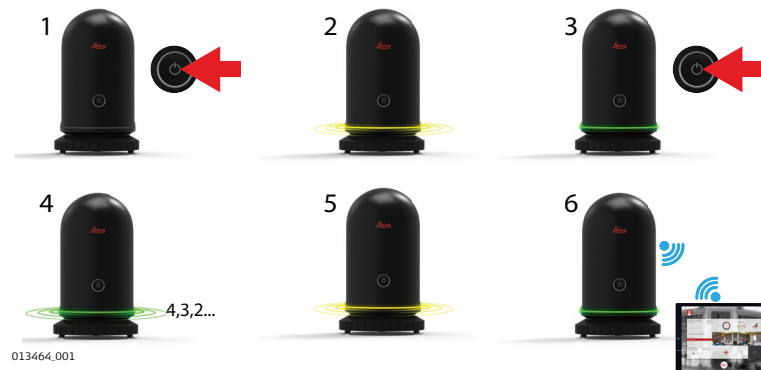

1. Press the power button to turn on the BLK360.
2. The BLK360 is starting. The ring-shaped LED is blinking yellow.
3. If the ring-shaped LED is continuous green, the BLK360 is ready for operation. Press the power button to start recording.
4. The BLK360 is counting down for 10 seconds before recording. The ring-shaped LED is blinking green.
5. Recording starts. The ring-shaped LED is blinking yellow.
6. The recording is finished. The ring-shaped LED is continuous green. The data transfer starts as soon as the BLK360 is linked to a computing device.



Do not touch or move the BLK360 while the system is recording.

Operation with computing device connection step-by-step

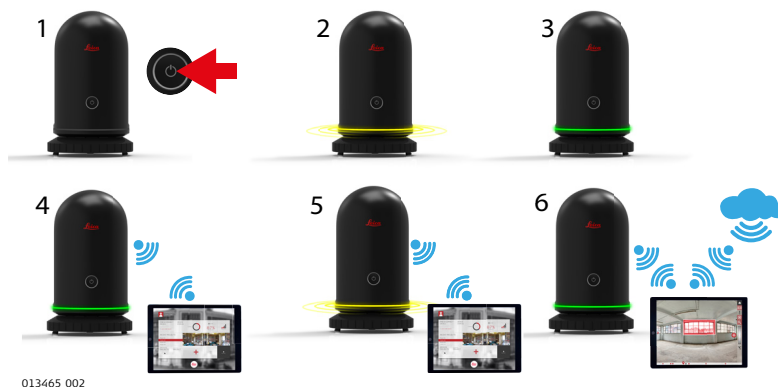

1. Press the power button to turn on the BLK360.
2. The BLK360 is starting. The ring-shaped LED is blinking yellow.
3. If the ring-shaped LED is continuous green, the BLK360 is ready for operation.
4. Connect the computing device with the BLK360.
5. Start the recording and simultaneous data transfer via computing device. The ring-shaped LED is blinking yellow.
6. Start the processing of data on the computing device.

Connecting to a computing device step-by-step



1. Start the BLK360 and wait until the LED is continuous green.
2. On the computing device select **Settings** and tap **Wi-Fi**.
3. Select the network **BLK360-35xxxxx** in the **Wi-Fi** settings to be connected.
 - ☞ The number **35xxxxx** is the serial number of the BLK360.
4. Enter the password.
 - ☞ The instrument specific password is printed on the label in the battery compartment (e.g. COL-123-456-789)
5. Start the app and connect the instrument.
 - ☞ For further information, refer to the help menu in the app.

Connecting to LAN infrastructure step-by-step

Connect the BLK360 via a USB-C Gigabit-Ethernet adapter to a LAN infrastructure in order to establish a cable connection to a PC for data download.



The Ethernet cable must be standard twisted, not crossed.
The maximum length of the Ethernet cable including the USB-C connector(s) must not exceed 3 meters.

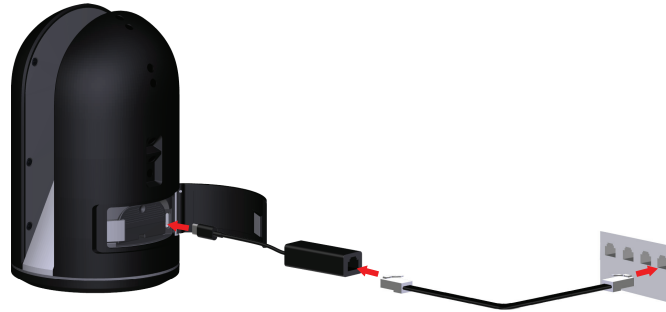

0022107_001

1. Start the BLK360.
2. Connect the USB-C Gigabit-Ethernet adapter to the BLK360.
3. Connect a network cable to the USB-C Gigabit-Ethernet adapter and the network wall socket.
4. On the computing device make sure that the PC is connected to the office network.
5. Start the app and connect with the instrument.
Data can be downloaded.

Configuration of the BLK360 for direct LAN communication step-by-step

1. Follow the steps described under [Connecting to a computing device step-by-step](#) and start the web interface by typing <http://192.168.10.90/> into your browser.



Google Chrome is not recommended.

2. Expand **Advanced Settings** and check **Enable direct LAN**.

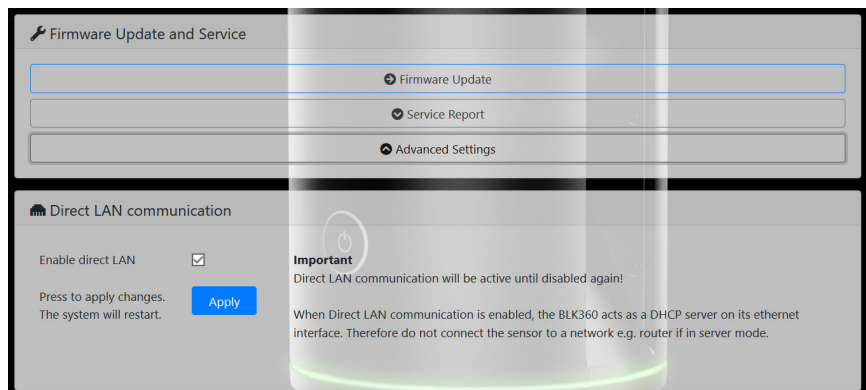

3. Click **Apply**.
The BLK360 is restarted automatically.
4. After the restart, the direct LAN communication to the computing device is available.



To enable and disable the direct LAN communication, use the WIFI connection to the BLK360.

Connecting to computing device using direct LAN communication step-by-step

In order to establish a cable connection to a computer for data download, the BLK360 must be connected to a computing device by a USB-C Gigabit-Ethernet adapter and a Ethernet cable.



The Ethernet cable must be standard twisted, not crossed. The maximum length of the Ethernet cable including the USB-C connector(s) must not exceed 3 meters.

1. Connect a LAN network cable to the USB-C Gigabit-Ethernet adapter.
2. Connect the USB-C connector to the BLK360. The USB-C port is on the right side of the battery compartment.
3. Connect the Ethernet cable to the Ethernet port of the computing device.

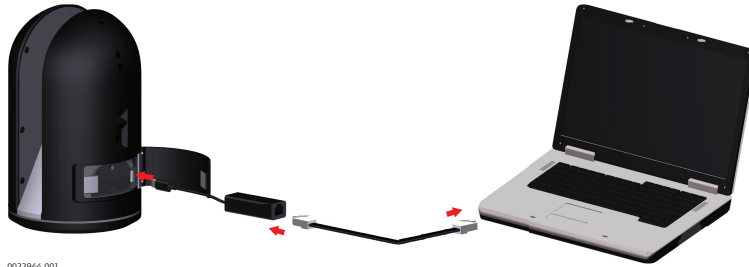

0022944.001

4. Start the Leica BLK Data Manager and connect with the instrument. Data can now be downloaded by cable.



If the computing device has no Ethernet port but a USB-C port, a second USB-C to Gigabit-Ethernet adapter can be used.



0022945.001



If the computing device uses a docking station to connect to the Internet, this Internet connection will be cut to connect to the BLK360. In most cases, a computing device only supports one LAN connection.

If the computing device is connected to the Internet over WLAN, this connection will remain.



If the instrument is in WIFI mode (LAN not enabled) but anyway connected to computing device over LAN, the BLK360 will start up and show an error (LED = red) for approximately 60 seconds to indicate that the current setup is not supported. Then the LED turns green and the BLK360 is useable over WIFI.



Once the direct LAN communication mode has been enabled, the BLK360 should not be connected to a router anymore, since it is acting as DHCP-server. This could lead to problems because normal routers are acting as DHCP-server too.

Recommended USB-C to Gigabit-Ethernet adapter

Brand	Model
HP	RTL8153-03
Belkin	F2CU040btBLK
Lenovo	4X90S91831

 An USB-C to Gigabit-Ethernet adapter is not provided by Leica Geosystems and must be purchased by the customer.

4.3

Imaging

Description

The BLK360 can collect two different types of image data:

- a HDR panoramic, 360 ° spheric image with three calibrated cameras
- a thermographic image with infrared camera (available in special product variant)

Imaging



4.4

Scanning

4.4.1

Ambient Conditions

Unfavourable surfaces for scanning

- Highly reflective (polished metal, gloss paint)
- Highly absorbent (black)
- Translucent (clear glass)

 Colour, powder or tape these surfaces before scanning if necessary.

Unfavourable weather conditions for scanning

- Rain, snow or fog may adversely affect measurement quality. Always use care when scanning in these conditions.
- Surfaces that are directly illuminated by the sun cause an increased range noise and therefore a larger measurement uncertainty.
- If some objects are scanned against the sunlight or a bright spotlight, the optical receiver of the instrument can be dazzled so heavily that in this area no measured data is recorded.

Temperature changes during scanning

If the instrument is brought from a cold environment, for example from storage, into a warm and humid environment, the mirror or in extreme cases even the interior optics can condense. This may cause measurement errors.

 Precaution: Avoid rapid temperature changes and give the instrument time to acclimatise.

Dirt on the rotating mirror-protection glass

Due to the encapsulated mirror design, the mirror is protected against direct contact. But dirt on the rotating mirror-protection glass such as a layer of dust, condensation or fingerprints may cause considerable measuring errors.

4.4.2

Troubleshooting



Basic troubleshooting

Problem	Possible Cause(s)	Suggested Remedies
Missing points in scan.	Dust, debris or fingerprints on the rotating mirror-protection glass.	Use a glass cleaning tissue to clean the specific areas.

Advanced troubleshooting

Problem	Possible cause	Suggested remedies
When switching on the instrument or starting a scan, the system switches off automatically.	Capacity of battery is too low. Battery not properly charged.	Recharge or change battery. Check the battery status as described in Power Supply .
The system switches off automatically, even though it was recharged, when switching on the instrument or starting a scan.	Battery charger is defective.	Check the function of the battery charger. Note the charging status displayed on the battery charger.
	Battery is no longer charging.	The battery has lost most of its capacity at the end of its life time. Replace the battery.

Troubleshooting-operation mode

LED status	Instrument status
	<p>System warning. For example, full storage device, empty battery. Shut down the instrument and reboot again.</p> <p>If status does not change, check internal storage capacity and power status of battery. Delete data and/or exchange battery.</p>
	<p>An unrecoverable system error occurred. Shut down the instrument and reboot again. If status does not change, contact the Leica support.</p>

4.4.3

Field of View (FoV)

Scanning laser - field of view

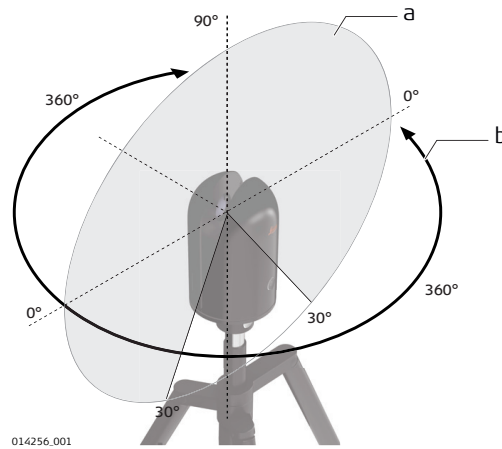

014256.001

- a Vertical field of view: 300°
- b Horizontal field of view: 360°

4.5

Data Transfer

Data Transfer from BLK360 to computing device



013477.002

- a Raw data transfer from BLK360 to computing device. Refer to [4.2 Operation - Getting Started](#).

Data transfer using LAN infrastructure

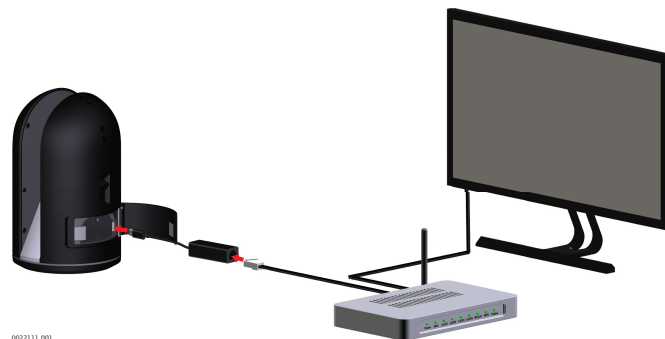

002211.001



The BLK360 must be in the same subnet of the network as the computer. Otherwise it can not be found e.g. by the BLK360 Data Manager.

Refer to [4.2 Operation - Getting Started](#) for a detailed description for setting up a connection.

Data transfer using direct LAN communication

Ethernet port on computing device

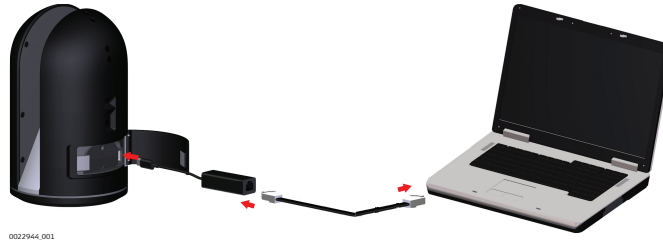

USB-C port on computing device



Refer to [4.2 Operation - Getting Started](#) for a detailed description for setting up a connection.

4.6

Power Supply

4.6.1

Battery and Charger Safety

General

Use the batteries, chargers and accessories recommended by Leica Geosystems to ensure the correct functionality of the instrument.

First-time use/ charging batteries

- The battery must be charged before using it for the first time because it is delivered with an energy content as low as possible
- The permissible temperature range for charging is from 0 °C to +40 °C/+32 °F to +104 °F. For optimal charging, we recommend charging the batteries at a low ambient temperature of +10 °C to +20 °C/+50 °F to +68 °F if possible
- It is normal for the battery to become warm during charging. Using the chargers recommended by Leica Geosystems, it is not possible to charge the battery once the temperature is too high
- For new batteries or batteries that have been stored for a long time (> three months), it is effectual to make only one charge/discharge cycle
- For Li-Ion batteries, a single discharging and charging cycle is sufficient. We recommend carrying out the process when the battery capacity indicated on the charger or on a Leica Geosystems product deviates significantly from the actual battery capacity available.

Operation/discharging

- The batteries can be operated from -20 °C to +55 °C/-4 °F to +131 °F.
- Low operating temperatures reduce the capacity that can be drawn; high operating temperatures reduce the service life of the battery.

4.6.2

Charging Station

Main components

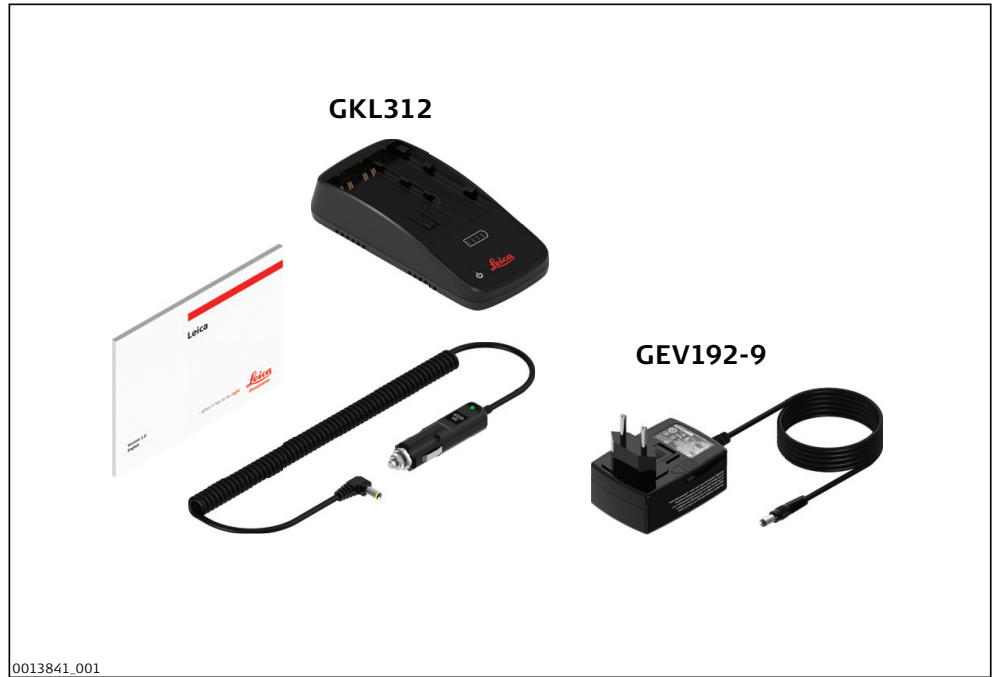

Power supply

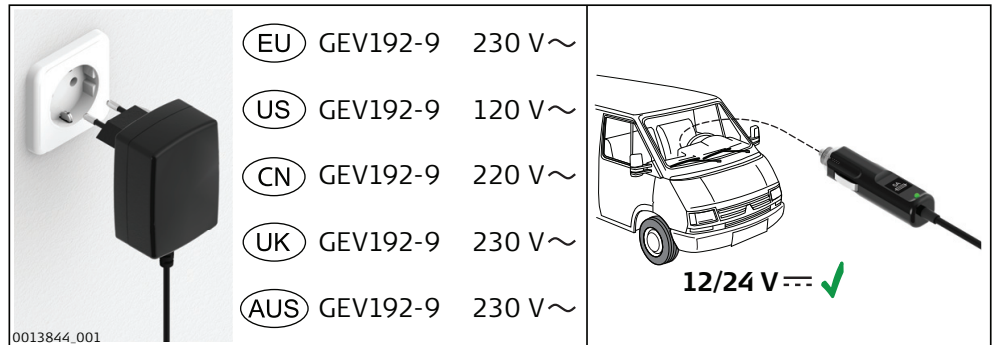

Charging times

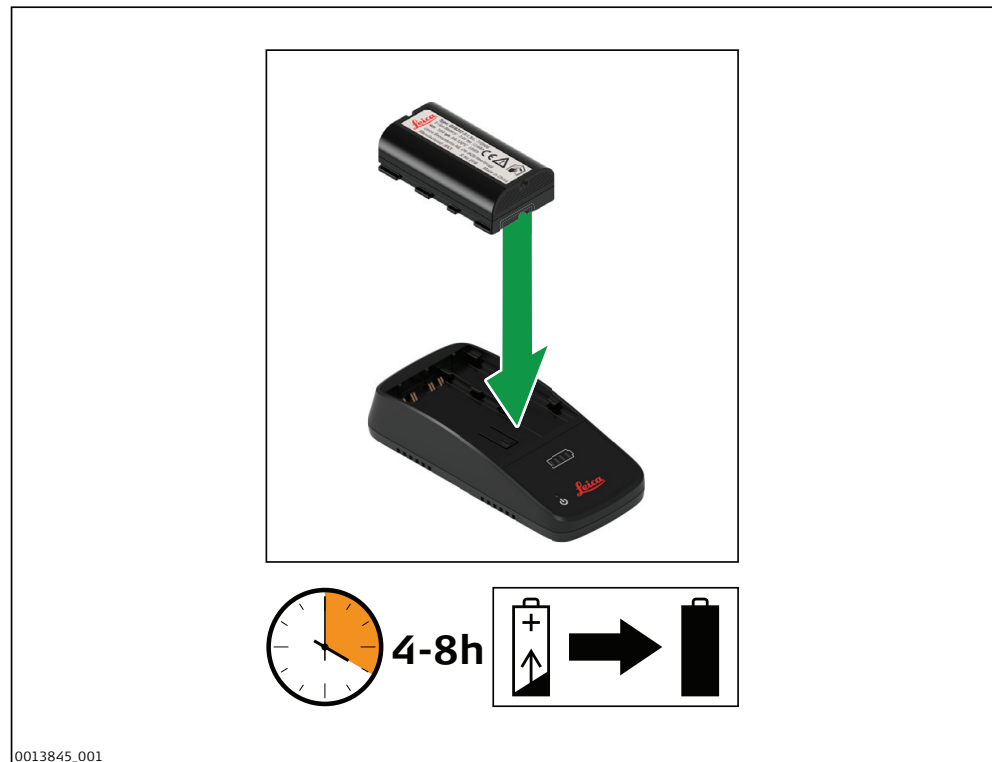

Connecting the charger

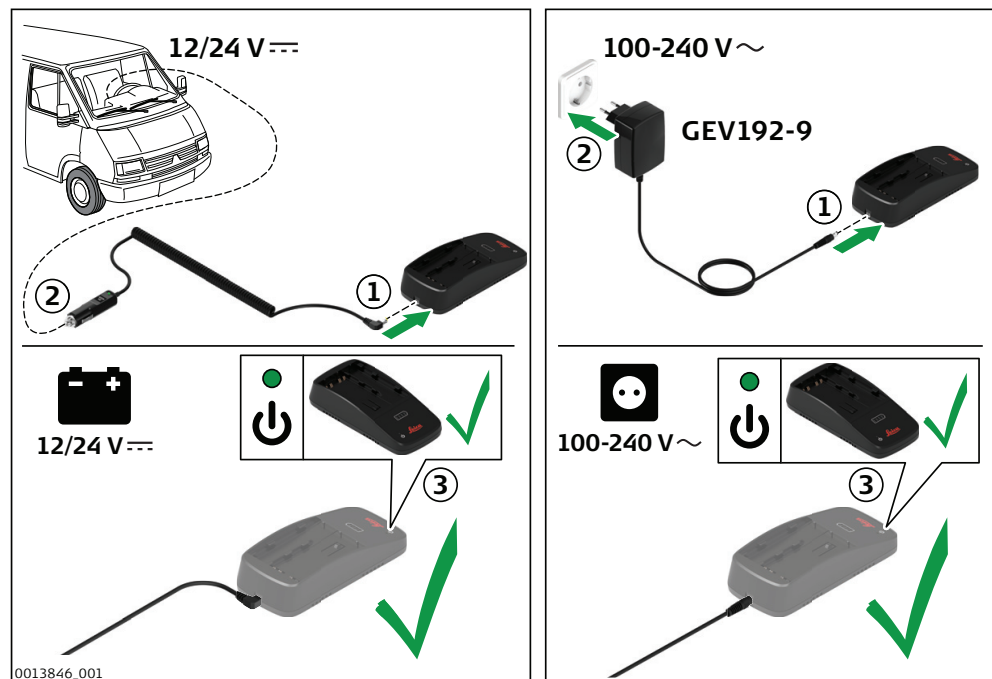

Inserting and charging the battery

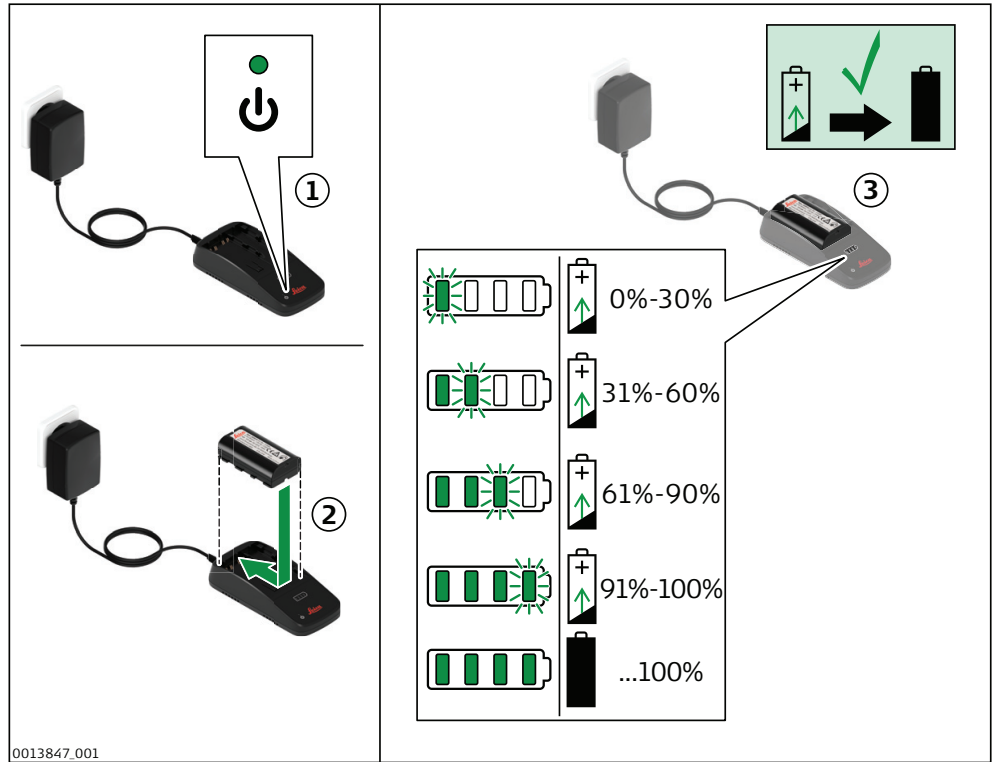

Error indication

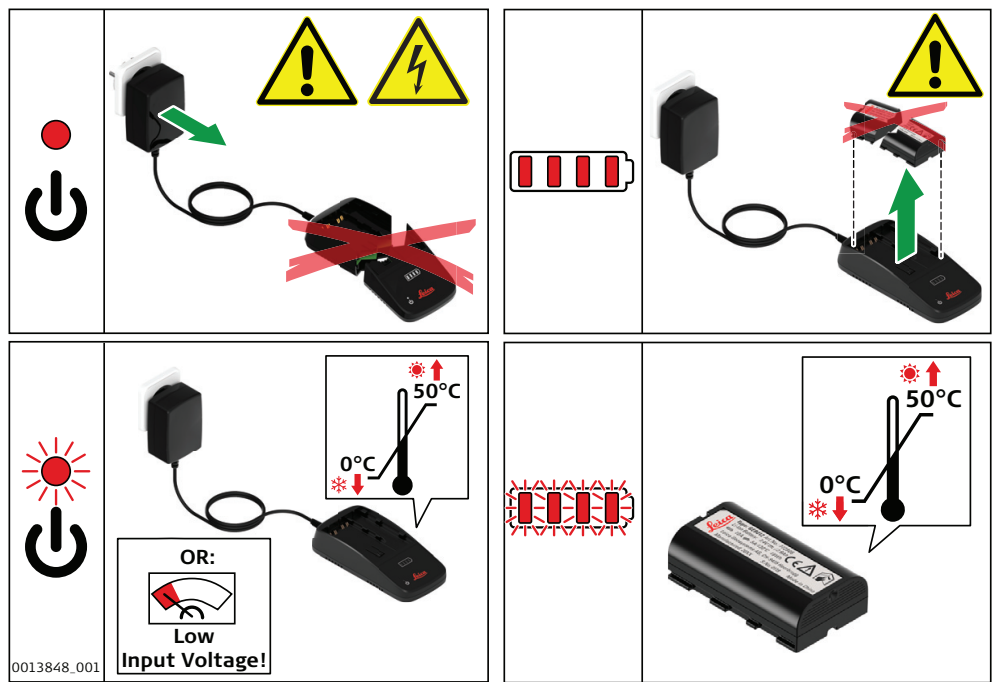

4.6.3

Internal Battery

Insert and remove the internal battery

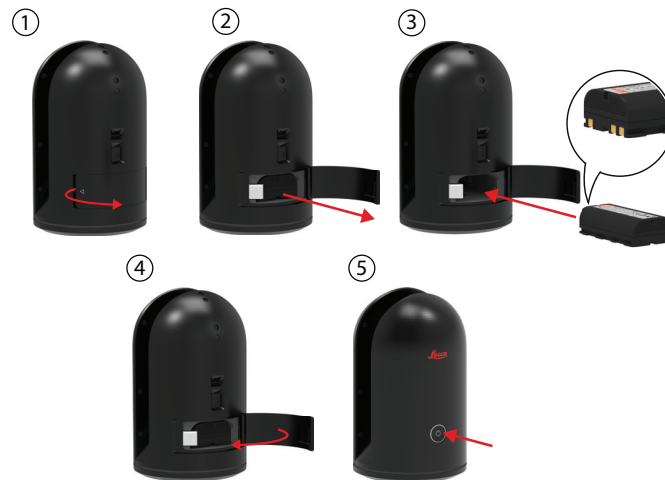

0014147_001

1. Open the battery compartment.
2. Remove the battery from the battery compartment.
3. Insert the new battery into the battery compartment.
☞ Ensure that the battery contacts are facing inwards.
4. Close the battery compartment.
5. Turn on the BLK360 to start the boot process.

NOTICE

Always shut down the instrument before removing the battery.

5 Care and Transport

5.1 Maintenance



For units that are exposed to high mechanical forces, for example through frequent transport or rough handling, it is recommended to carry out test measurements periodically.

5.2 Transport

Transport in the field

When transporting the equipment in the field, always make sure that you carry the product in its original transport container or carry the tripod upright with the product fastened and secured onto the tripod.

Transport in a road vehicle

Never carry the product loose in a road vehicle, as it can be affected by shock and vibration. Always carry the product in its container and secure it.

For products for which no container is available use the original packaging or its equivalent.

Shipping

When transporting the product by rail, air or sea, always use the complete original Leica Geosystems packaging, container and cardboard box, or its equivalent, to protect against shock and vibration.

Shipping, transport of batteries

When transporting or shipping batteries, the person responsible for the product must ensure that the applicable national and international rules and regulations are observed. Before transportation or shipping, contact your local passenger or freight transport company.

5.3 Storage

BLK360

Respect the temperature limits when storing the equipment, particularly in summer if the equipment is inside a vehicle. Refer to [6 Technical Data](#) for information about temperature limits.

5.4 Cleaning and Drying

Damp products

Dry the product, the mission bag, the foam inserts and the accessories at a temperature not greater than 40°C /104°F and clean them. Remove the battery cover and dry the battery compartment. Do not repack until everything is completely dry. Always close the mission bag when using in the field.

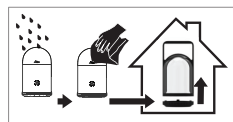

Housing parts of product and accessories

- Never touch the glass surfaces or the rotating mirror-protection glass with your fingers.
- Only use a clean, soft, lint-free cloth for cleaning. If necessary, moisten the cloth with water or pure alcohol. Do not use other liquids; other liquids may attack the polymer components.

Charger and AC/DC power supply

Use only a clean, soft, lint-free cloth for cleaning.

Cables and plugs

Keep plugs clean and dry. Blow away any dirt lodged in the plugs of the connecting cables.

5.5

Glass Cleaning Procedure

General cleaning information

The scanning mirror must be kept clean. The instructions must be followed as described in this chapter to clean the scanner mirror.

CAUTION

Before any cleaning procedure, ensure that the instrument is switched off and the battery has been removed.

Dust and debris on optical surfaces

Using a compressed gas duster (e.g., UltraJet® 2000 Gas Duster or UltraJet® Compressed CO2 Duster), remove dust and debris from surface of scanner glass.



Never rub off dust or debris as this will scratch the glass and so possibly cause permanent damage to the special optical coatings.

Cleaning of optical surfaces

Soiling of the glass pane can cause extreme measurement errors and therefore useless data!



All soiling that is visible on the glass pane has to be removed, except for single small dust particles that adhere inevitably.

For the glass cleaning procedure, the wet and dry lens cleaner Green Clean LC-7010 is recommended (www.green-clean.at/en.html).

Clean the glass pane regularly with the recommended cleaning tissue:

- Switch off instrument and remove the battery.
- Washing hands is necessary in order to avoid grease on the cleaning tissue.
- Better, use gloves to avoid finger oil on the glass.
- Then use the wet lens cleaning tissue (Green Clean LC-7010) until there is only a thin film of detergent visible.
- After that use the dry lens cleaning tissue (Green Clean LC-7010) to remove any remaining detergent.
- If any smears from cleaning are visible against back light, repeat the procedure.
- Do not use air from the pneumatic power system as this is always slightly oily!

6 Technical Data

6.1 General Technical Data of the Product

Storage and Communication

Internal storage:

32 GB, enough for > 100 setups

Communication:

Type	Description
WLAN	Integrated 802.11 b/g/n WLAN with MIMO
LAN	USB-C Gigabit-Ethernet port network connection using a USB-C Gigabit-Ethernet/RJ45 adapter

Internal HDR cameras

The Leica BLK360 has three integrated HDR digital cameras.

Camera data	Value
Type	Colour sensor, fixed focal length
Single image	2592 x 1944 pixels, 60° x 45° (V x Hz)
Full dome	30 images, automatically spatially rectified, 150Mpx, 360° x 300°
White balancing	Automatic
HDR	Automatic
Flash	LED for continuous illumination
Minimum range	0.6 m

6.2 System Performance

System performance and accuracy



All \pm accuracy specifications are one sigma (1σ) under Leica Geosystems standard test conditions unless otherwise noted.

Accuracy of single measurement (at 78% albedo)	Value
Angle (horizontal/vertical)	40"/40"
3D point accuracy	6 mm at 10 m, 8 mm at 20 m

6.3 Laser System Performance

Laser scanning system data



The scanning system is a high speed time-of-flight unit, enhanced by Waveform Digitising (WFD) technology with a maximum scan rate of 360.000 points/second.

Laser unit:

Scanning laser	Value
Classification	Laser Class 1 (in accordance with IEC 60825-1 (2014-05))
Wavelength	830 nm (invisible)

Range:

Scanning data	Value
Beam divergence	0.4 mrad (FWHM, full angle)
Beam diameter at front window	2.25 mm (FWHM)
Minimum range	0.6 m
Maximum range	60 m @ 78% albedo
Range accuracy	4 mm at 10 m and 7 mm at 20 m

Field-of-View (per scan):

Field-of-View	Value
Selection	Always full dome.
Horizontal	360°
Vertical	300°
Scanning optics	Vertically rotating mirror on horizontally rotating base.

Scan duration for 3 settings:

Point density mode	Resolution [mm @ 10m]	Estimated scan duration [MM:SS] for a full dome scan
Fast	35	00:40
Standard	10	01:50
High density	5	03:40

Image capturing time:

Camera type	Estimated image duration [MM:SS]
Non HDR	01:00
HDR	02:30
Thermal	00:30

Scan size for 3 settings:

Resolution [mm @ 10m]	Approx. scan size [mio points]
Fast	3
Standard	18
High density	65

6.4

Electrical Data

BLK360 power supply and consumption

Power supply:

Internal battery

7.4V DC; one internal battery provided with system.

Power consumption:

Instrument

10 W typical; 16 W max.

GKL312 charging station

Supply	Value
Input voltage	10-32 V DC

GEB212 internal battery

Supply	Value
Type	Li-Ion
Voltage	7.4 V
Capacity	2.6 Ah

Battery operating and charging times

Internal battery	Value
Operating time	> 40 setups per battery, typical continuous use (room temperature).
Charging time	Typical charging time with charger GKL312 is 4-8 hours at room temperature.

6.5

Environmental Specifications

6.5.1

BLK360

Environmental specifications BLK360

Temperature range:

Type	Operating temperature [°C]	Storage temperature [°C]
Instrument	+5 to +40	-25 to +70

Protection against water, dust and sand:

Type	Protection
Instrument	IP54 (IEC 60529), upright, battery door closed Dust protected Protection against splashing water from any direction

Humidity:

Type	Protection
Instrument	Max 95 % non condensing

Lighting:

Type	Conditions
Instrument	Fully operational from bright sunlight to complete darkness.

6.5.2**Charger and Batteries****Charger and battery specifications****Temperature range for GKL312 and GEB212**

Operating temperature [°C]	Mode
0 to +50	Charging
-20 to +55	Discharging
Storage temperature [°C]	
-40 to +70	

Protection against water, dust, sand and humidity

Type	Protection
Battery	IP54 (IEC 60529) Dust protected Protection against splashing water from any direction. Humidity max. 95% non condensing.
Type	Protection
Charger and AC/DC power supply	Only operate in dry environments, for example in buildings and vehicles.

6.6**Dimensions****Dimensions**

Instrument	Dimensions [mm] (D x W x H)	Dimensions ["] (D x W x H)
Leica BLK360	100.3 x 100.3 x 165	3.9 x 3.9 x 6.5
GEV192-9 AC power supply for charging station GKL312	85 x 170 x 41 / cable length: 1800	3.4 x 6.7 x 1.6 / cable length: 70
GKL312 charging station	157 x 71 x 38	6.2 x 2.8 x 1.5
GEB212 battery	71.5 x 39.5 x 21.2	2.8 x 1.6 x 0.8
GAD123 tripod adapter	42 x 42 x 35.1	1.65 x 1.65 x 3.1

Instrument	Dimensions [mm] (D x W x H)	Dimensions ["] (D x W x H)
Transport container	195.5 x 195.5 x 258.6	7.7 x 7.7 x 10.2

Instrument dimensions

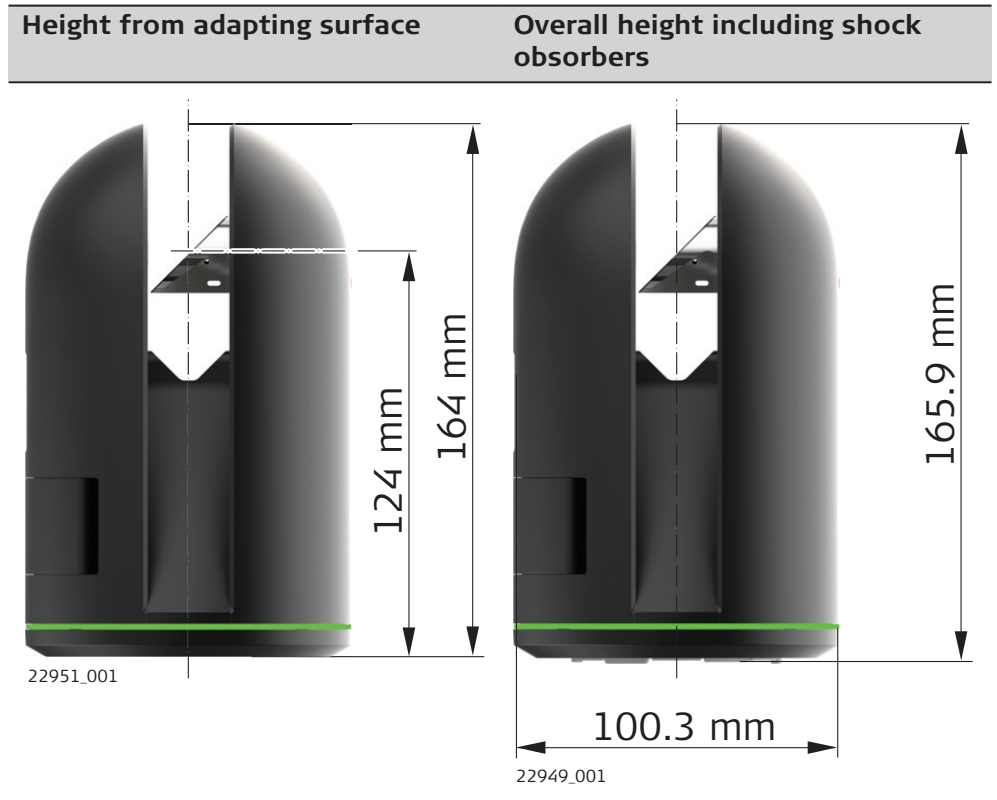

Special cases

Setup	Height of elevation axis = Height from adapting surface
On a tripod using GAD123 tripod adapter	149 mm above tripod = 124 mm + 25 mm
On table using rubber shock absorbing feed	125.9 mm = 124 mm + 1.9 mm

Dimensions of tripod adapter

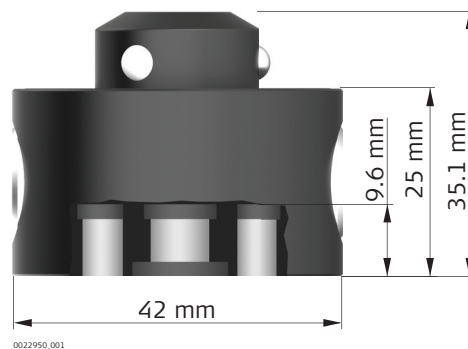

6.7

Weight

Weight

Instrument	Weight [kg]	Weight [lbs]
Leica BLK360	1.0 nominal	2.2 nominal
GEV192-9 AC power supply for GKL312	0.1	0.3
GKL312 charging station	0.1	0.3
GEB212 battery	0.1	0.3
Leica BLK360 transport container (without scanner and accessories)	1.0	2.3
Leica BLK360 transport container (with scanner and standard accessories)	3.0	6.7

6.8

Accessories

Scope of delivery

Included standard accessories:

- BLK360 hood
- Battery charger GKL312 with AC power adapter GEV192-9
- Battery GEB212 (1x)
- Quick guide BLK360
- Quick guide GKL312
- 12 month warranty
- Calibration certificate digital access via online registration

Additional accessories

- additional batteries GEB212
- BLK360 tripod
- BLK360 tripod adapter
- BLK360 mission bag
- BLK360 tribrach adapter

6.9

Conformity to National Regulations

6.9.1

BLK360

Conformity to national regulations

- FCC Part 15 (applicable in US)
 - Hereby, Leica Geosystems AG declares that the radio equipment type BLK360 is in compliance with Directive 2014/53/EU and other applicable European Directives.
The full text of the EU declaration of conformity is available at the following Internet address: <http://www.leica-geosystems.com/ce>.
-  Class 1 equipment according to European Directive 2014/53/EU (RED) can be placed on the market and be put into service without restrictions in any EEA member state.
- The conformity for countries with other national regulations not covered by the FCC part 15 or European Directive 2014/53/EU has to be approved prior to use and operation.

Japanese Radio Law Compliance:

- This device is granted pursuant to the Japanese Radio Law (電波法).
- This device should not be modified (otherwise the granted designation number will become invalid).

Frequency band

Type	Frequency band [MHz]
WLAN	2412 - 2462

Output power

Type	Output power [mW]
WLAN	100 max.

Antenna

Type	Antenna	Gain [dBi]
WLAN	Dual dipole antenna MIMO system	± 2



6.9.2

Dangerous Goods Regulations

Dangerous Goods Regulations

Many products of Leica Geosystems are powered by Lithium batteries.

Lithium batteries can be dangerous under certain conditions and can pose a safety hazard. In certain conditions, Lithium batteries can overheat and ignite.

-  When carrying or shipping your Leica product with Lithium batteries onboard a commercial aircraft, you must do so in accordance with the **IATA Dangerous Goods Regulations**.
-  Leica Geosystems has developed **Guidelines** on "How to carry Leica products" and "How to ship Leica products" with Lithium batteries. Before any transportation of a Leica product, we ask you to consult these guidelines on our web page (<http://www.leica-geosystems.com/dgr>) to ensure that you are in accordance with the IATA Dangerous Goods Regulations and that the Leica products can be transported correctly.
-  Damaged or defective batteries are prohibited from being carried or transported onboard any aircraft. Therefore, ensure that the condition of any battery is safe for transportation.

Software Licence Agreement

This product contains software that is preinstalled on the product, or that is supplied to you on a data carrier medium, or that can be downloaded by you online according to prior authorisation from Leica Geosystems. Such software is protected by copyright and other laws and its use is defined and regulated by the Leica Geosystems Software Licence Agreement, which covers aspects such as, but not limited to, Scope of the Licence, Warranty, Intellectual Property Rights, Limitation of Liability, Exclusion of other Assurances, Governing Law and Place of Jurisdiction. Please make sure, that at any time you fully comply with the terms and conditions of the Leica Geosystems Software Licence Agreement.

Such agreement is provided together with all products and can also be referred to and downloaded at the Leica Geosystems home page at <http://leica-geosystems.com/about-us/compliance-standards/legal-documents> or collected from your Leica Geosystems distributor.

You must not install or use the software unless you have read and accepted the terms and conditions of the Leica Geosystems Software Licence Agreement. Installation or use of the software or any part thereof, is deemed to be an acceptance of all the terms and conditions of such Licence Agreement. If you do not agree to all or some of the terms of such Licence Agreement, you must not download, install or use the software and you must return the unused software together with its accompanying documentation and the purchase receipt to the distributor from whom you purchased the product within ten (10) days of purchase to obtain a full refund of the purchase price.

Open source information

The software on the product may contain copyright-protected software that is licensed under various open source licences.

Copies of the corresponding licences:

- are provided together with the product (for example in the About panel of the software).
- can be downloaded on <http://opensource.leica-geosystems.com/blk360>.

If foreseen in the corresponding open source licence, you may obtain the corresponding source code and other related data on <http://opensource.leica-geosystems.com/blk360>. Contact opensource@leica-geosystems.com in case you need additional information.



853811-4.0.0en

Original text

Printed in Switzerland, © 2021 Leica Geosystems AG



- when it has to be **right**



Leica Geosystems AG

Heinrich-Wild-Strasse
9435 Heerbrugg
Switzerland

www.leica-geosystems.com

